

I VACUUM CLEANER TYPE ZELMER 1117.6E
KOLOR RAL 3011
KOLOR RAL 4007 / ZELMER HUNGARY
KOLOR Z - 2046

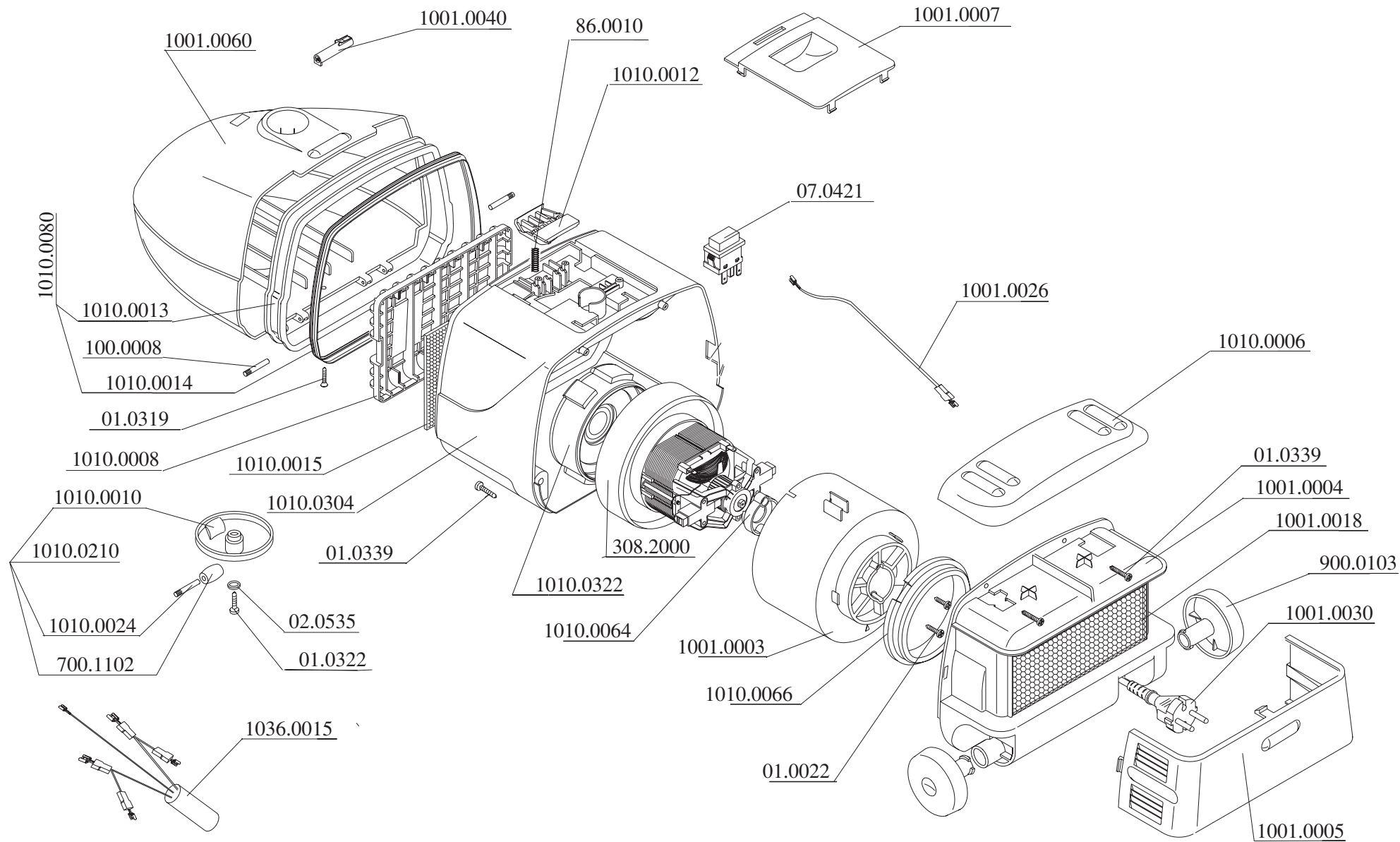

IV VACUUM CLEANER ACCESSORIES
KOLOR RAL 3011
TYPE ZELMER 1117.6E KOLOR RAL 4007 / ZELMER HUNGARY
KOLOR Z - 2046

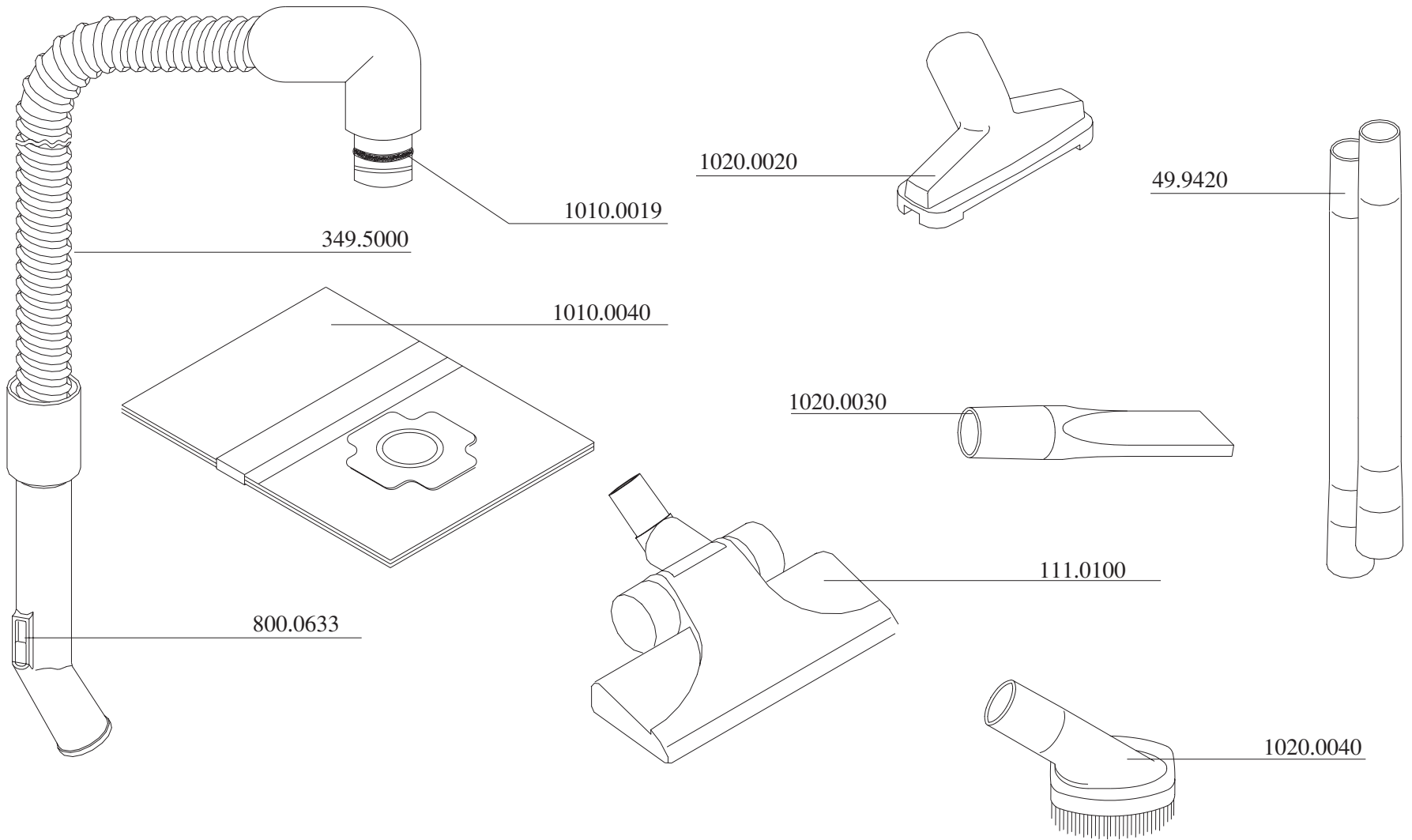

**V ELECTRICAL DIAGRAM OF THE VACUUM CLEANER
(KOLOR RAL 3011)
ZELMER 1117.6E (KOLOR RAL 4007) / ZELMER HUNGARY
(KOLOR Z – 2046)**

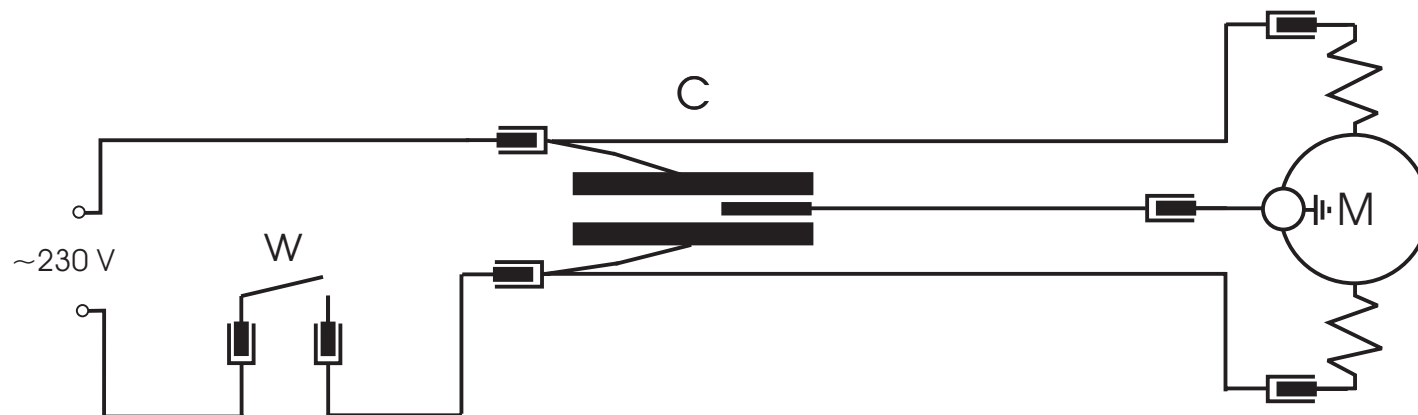

- M -suction unit
- W -main switch
- C -capacitor