

I VACUUM CLEANER
ZELMER TYPE 1117 K (RED RAL 3011)
ZELMER HUNGARY

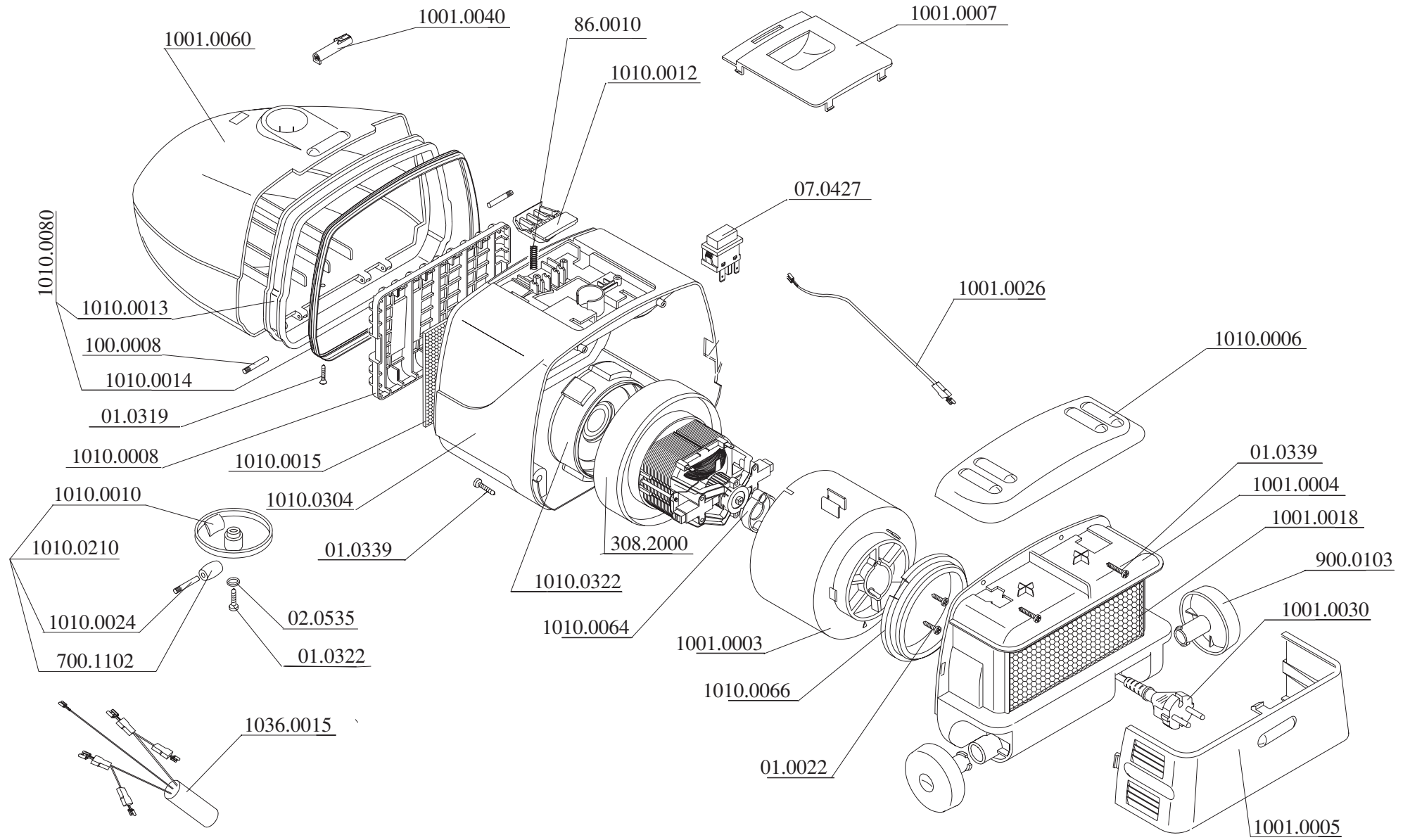

II SUCTION UNIT TYPE 308.2000

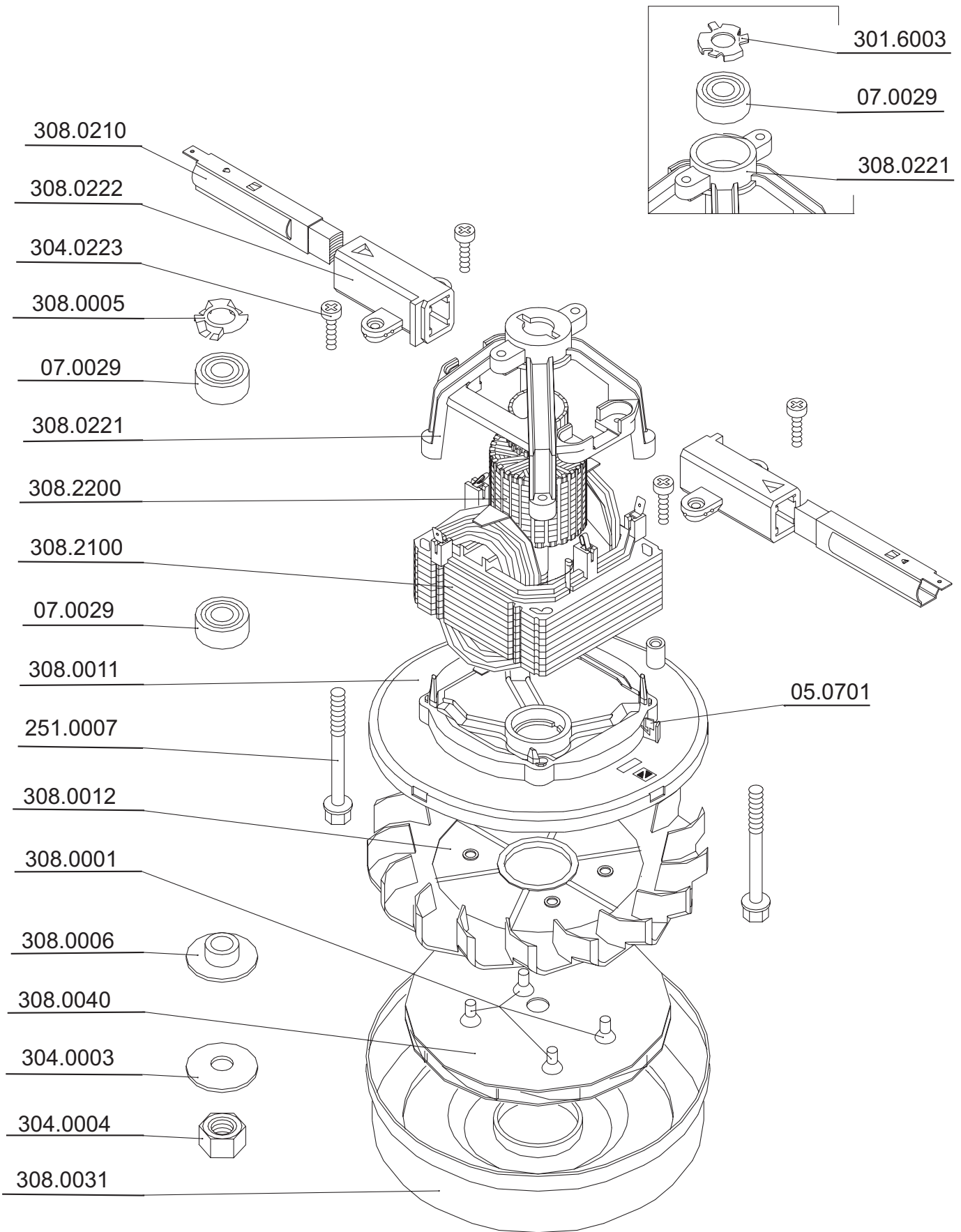

IV VACUUM CLEANER ACCESSORIES
ZELMER TYPE 1117 K (RED RAL 3011)
ZELMER HUNGARY

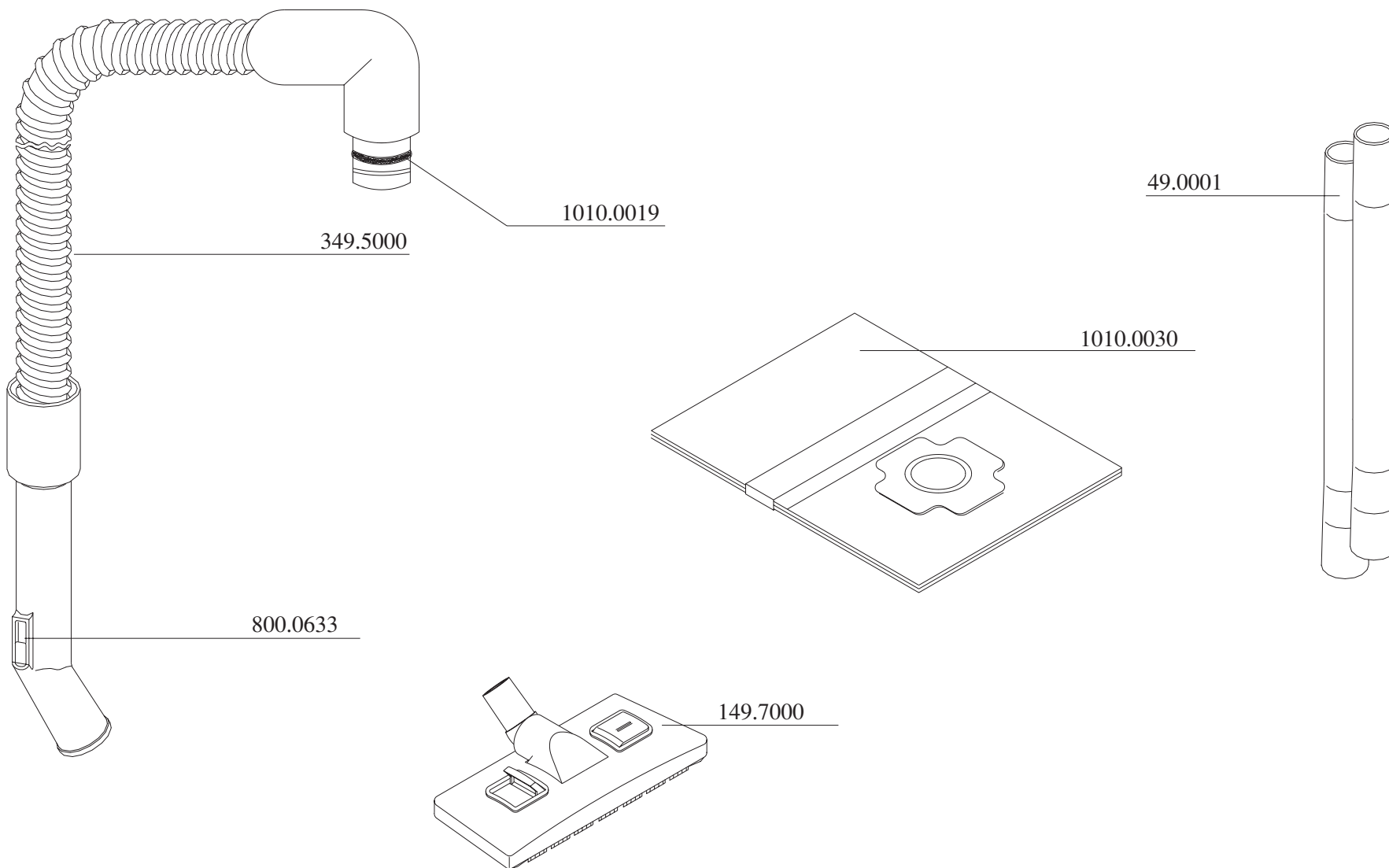

**V ELECTRICAL DIAGRAM OF THE VACUUM CLEANER
ZELMER TYPE 1117 K (RED RAL 3011)
ZELMER HUNGARY**

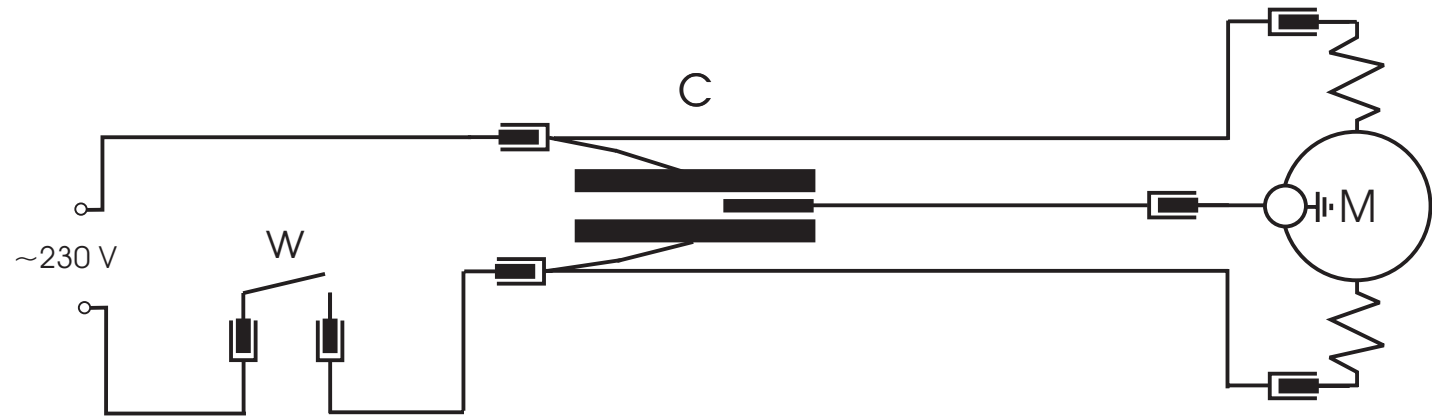

- M -suction unit
- W -main switch
- C -capacitor