

I VACUUM CLEANER ZELMER TYPE 1117 T
LIGHT YELLOW PANTONE 121C
LIGHT ORANGE PANTONE 137C
ZELMER HUNGARY

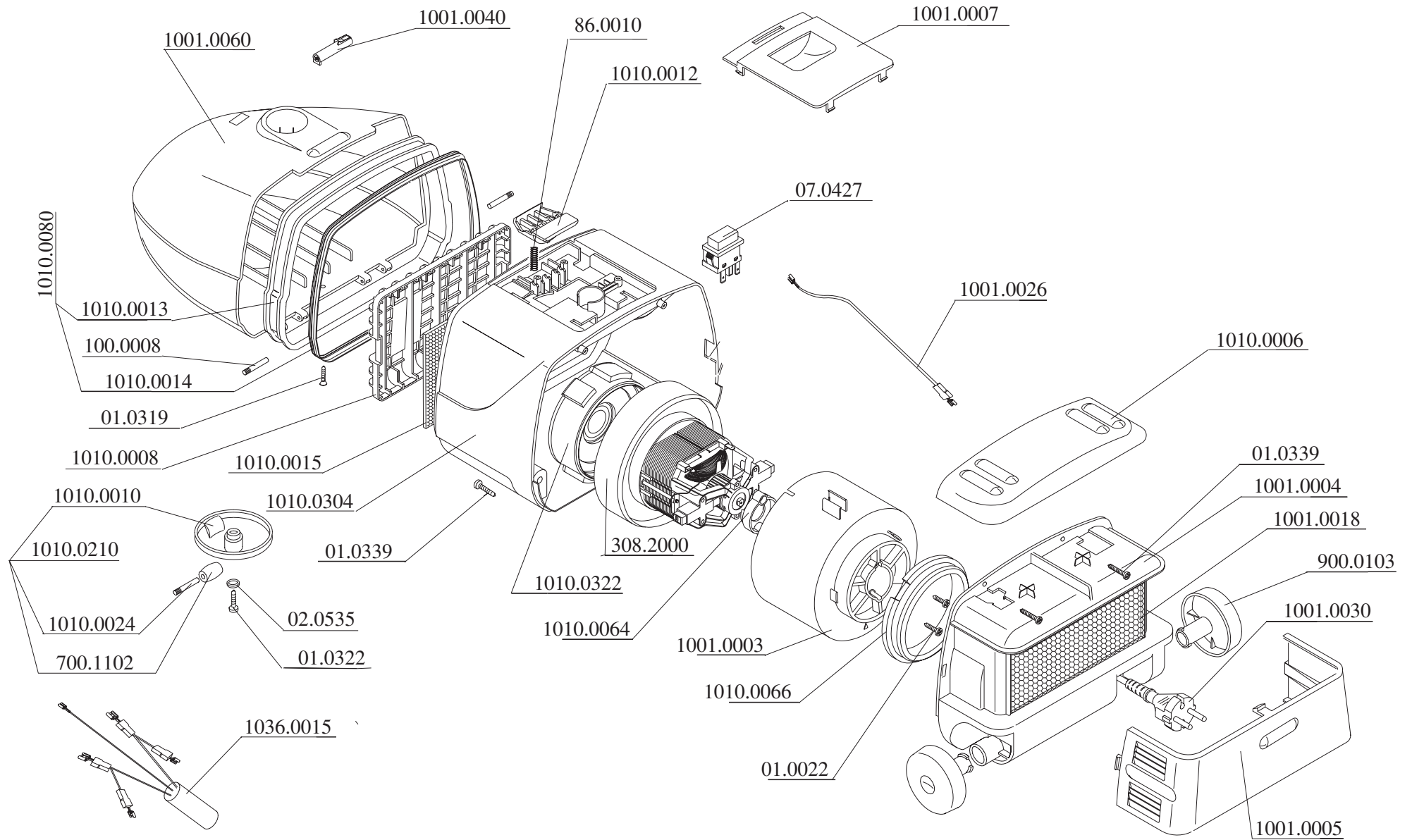

IV VACUUM CLEANER ACCESSORIES

ZELMER TYPE 1117 T

LIGHT YELLOW PANTONE 121C

LIGHT ORANGE PANTONE 137C

ZELMER HUNGARY

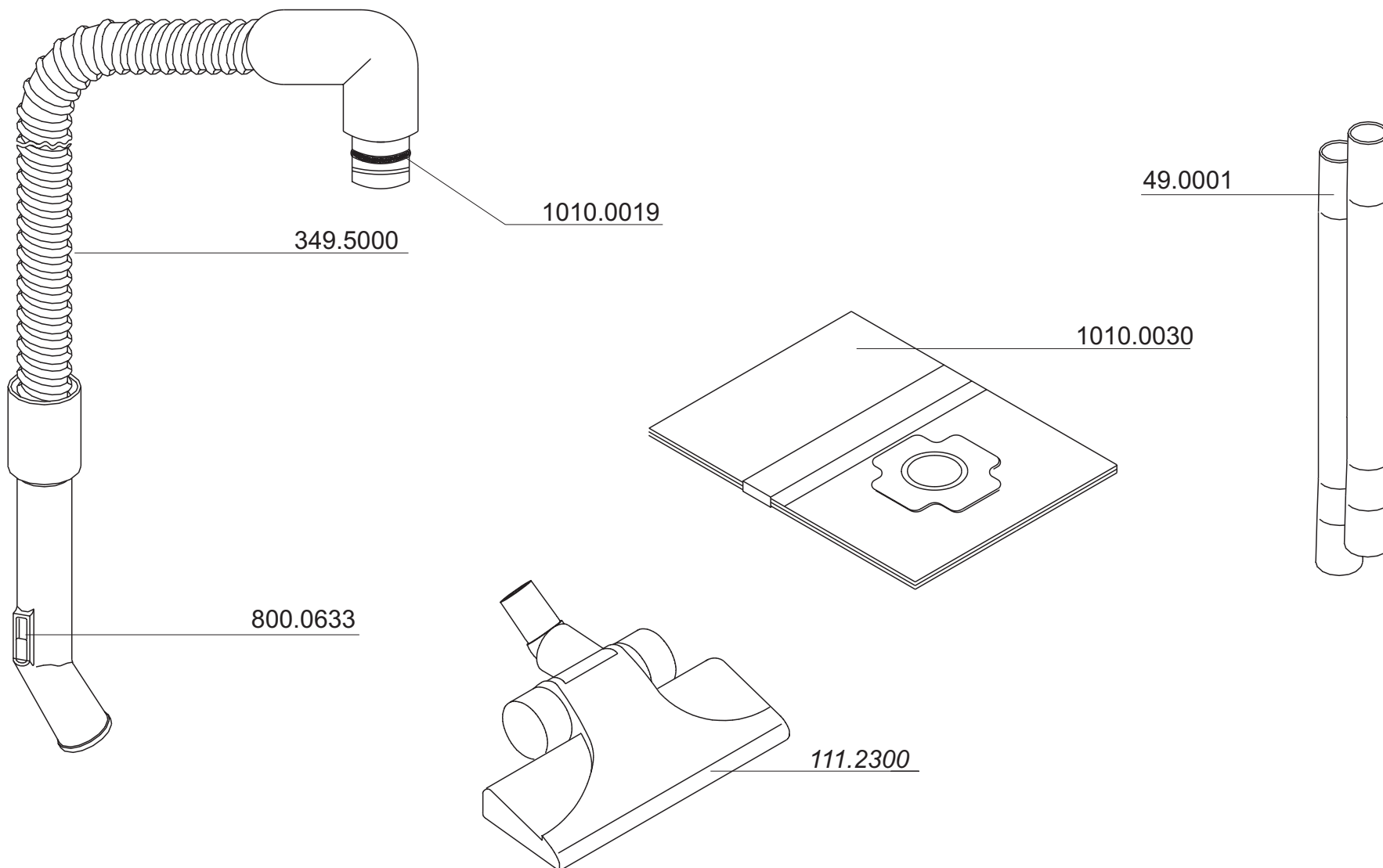

**V ELECTRICAL DIAGRAM OF THE VACUUM CLEANER
ZELMER TYPE 1117 T
ZELMER HUNGARY**

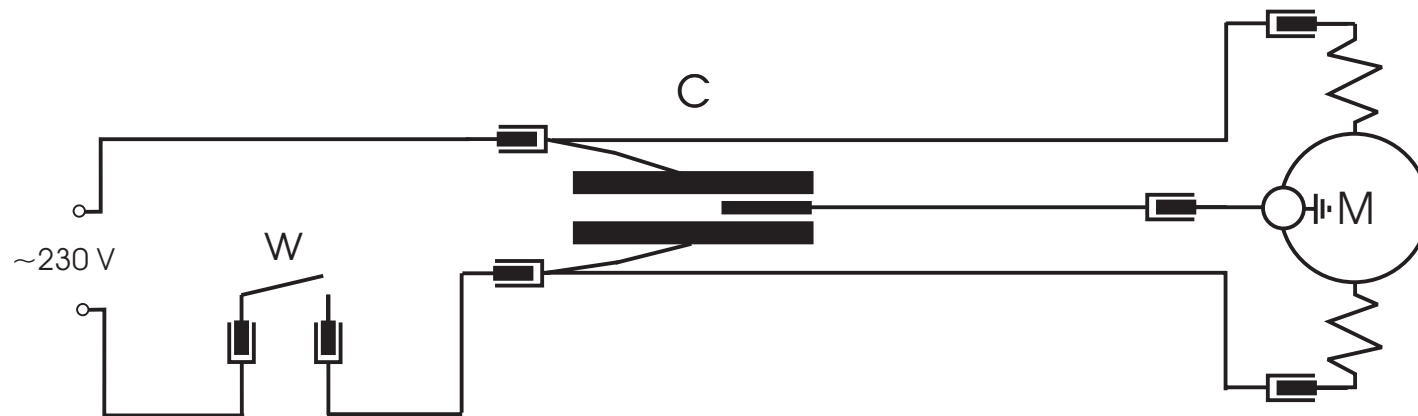

- M -suction unit
- W -main switch
- C -capacitor