

I VACUUM CLEANER ZELMER TYPE 1117 TM (RED RAL 3010) ZELMER HUNGARY

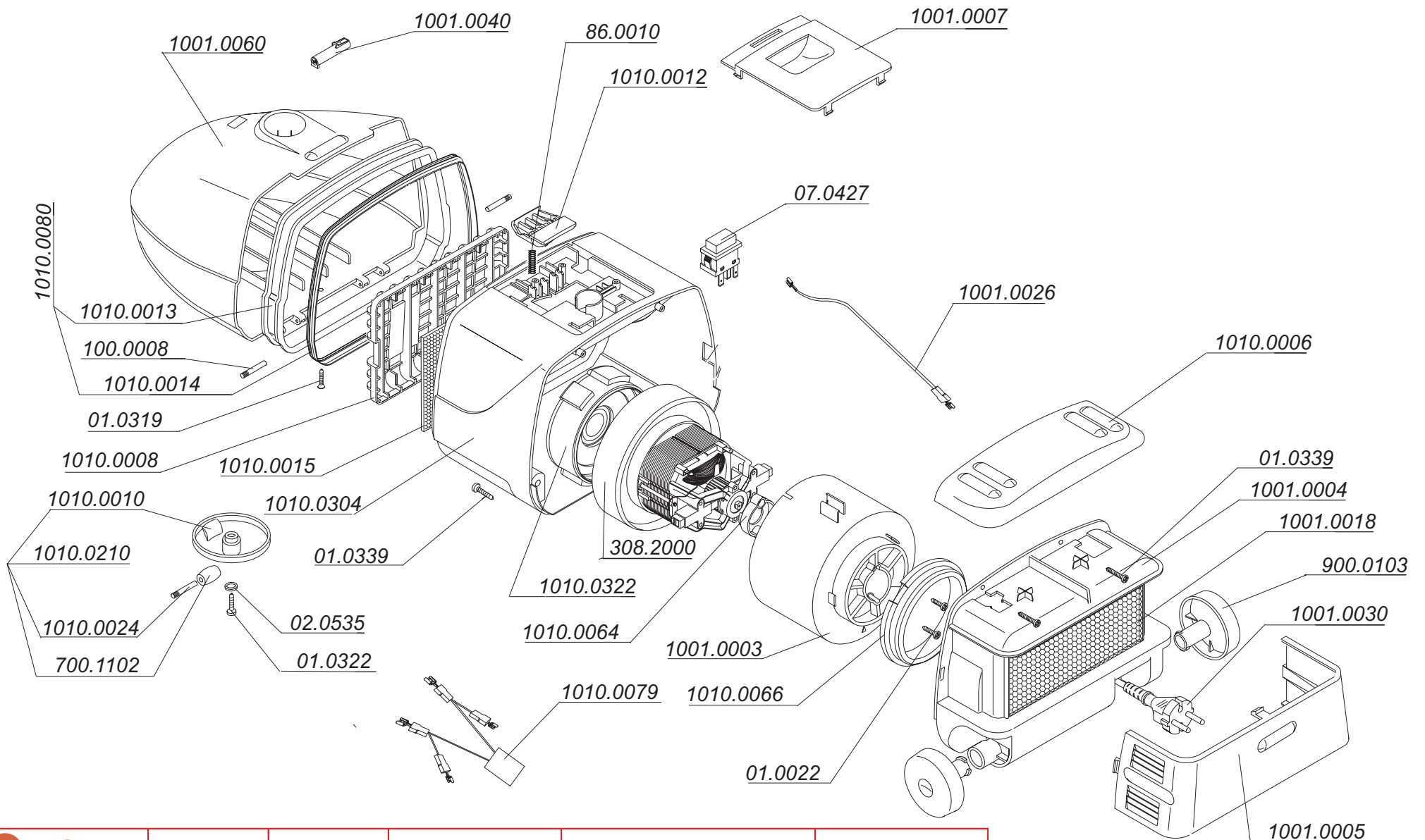

II SUCTION UNIT TYPE 308.2000

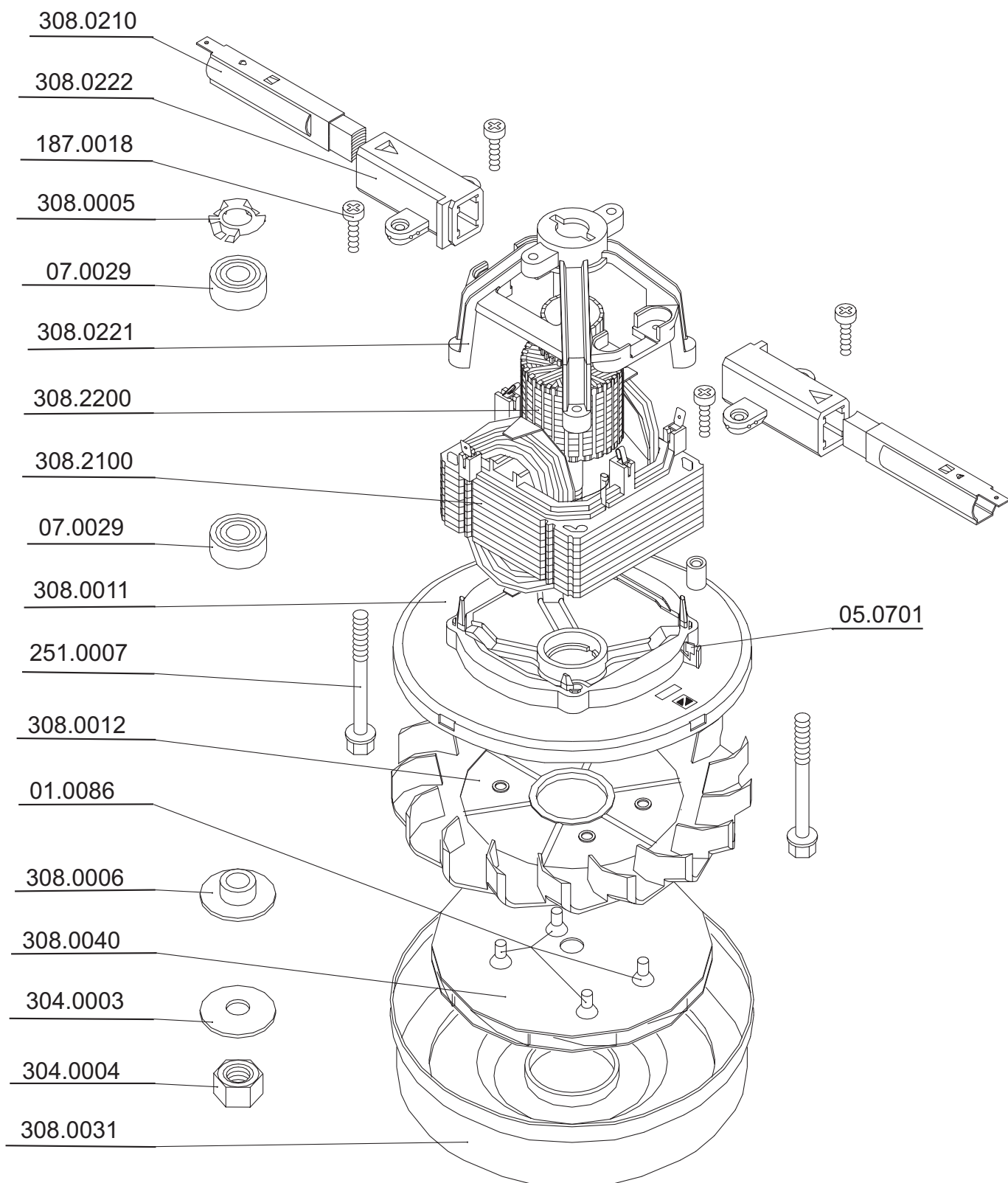

IV VACUUM CLEANER ACCESSORIES
ZELMER TYPE 1117 TM
(RED RAL 3010)
ZELMER HUNGARY

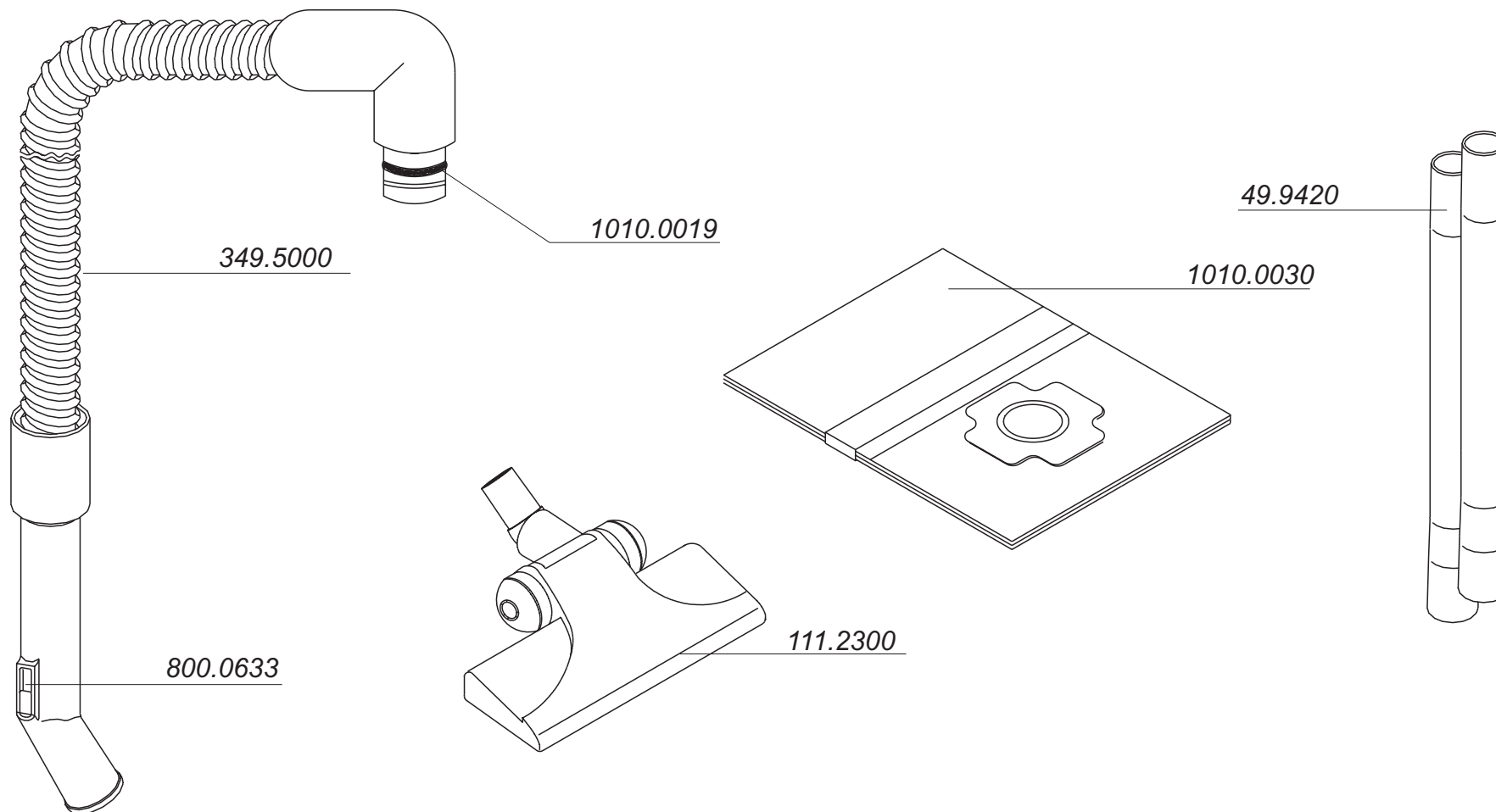

V ELECTRICAL DIAGRAM OF THE VACUUM CLEANER
ZELMER TYPE 1117 TM
ZELMER HUNGARY

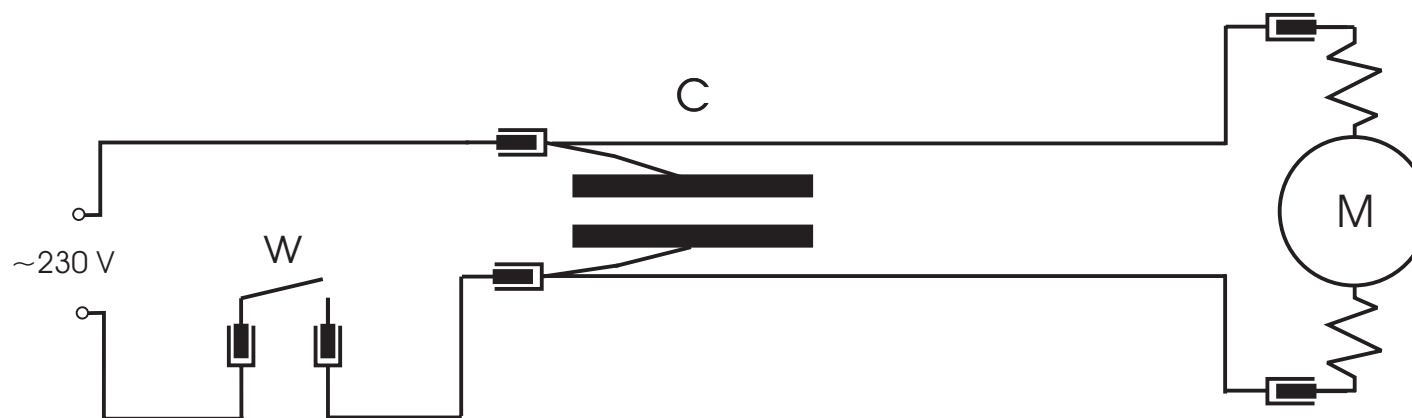

- M -suction unit
- W -main switch
- C -capacitor