

II SUCTION UNIT TYPE 308.4000

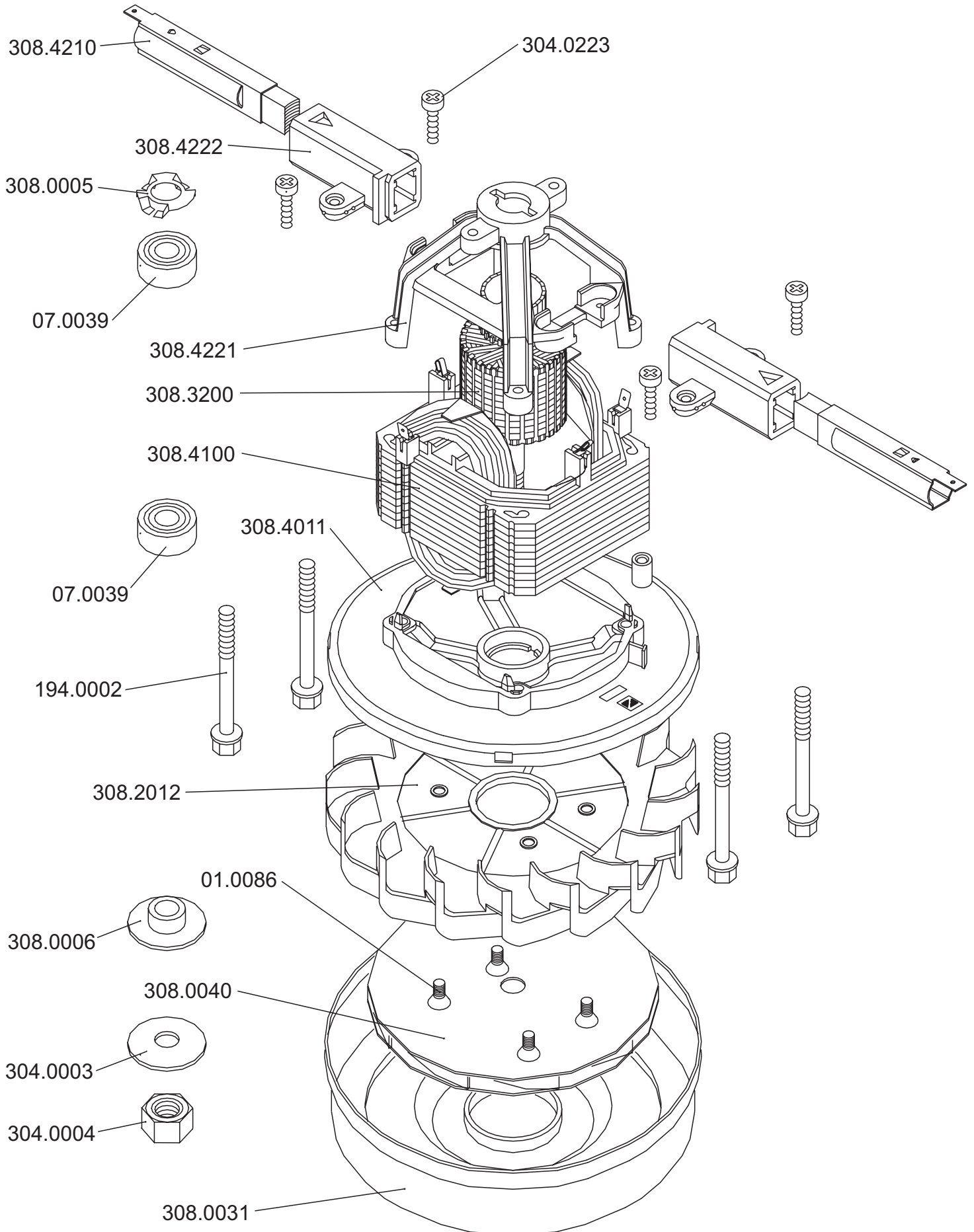

III CORD WINDER 269.0000

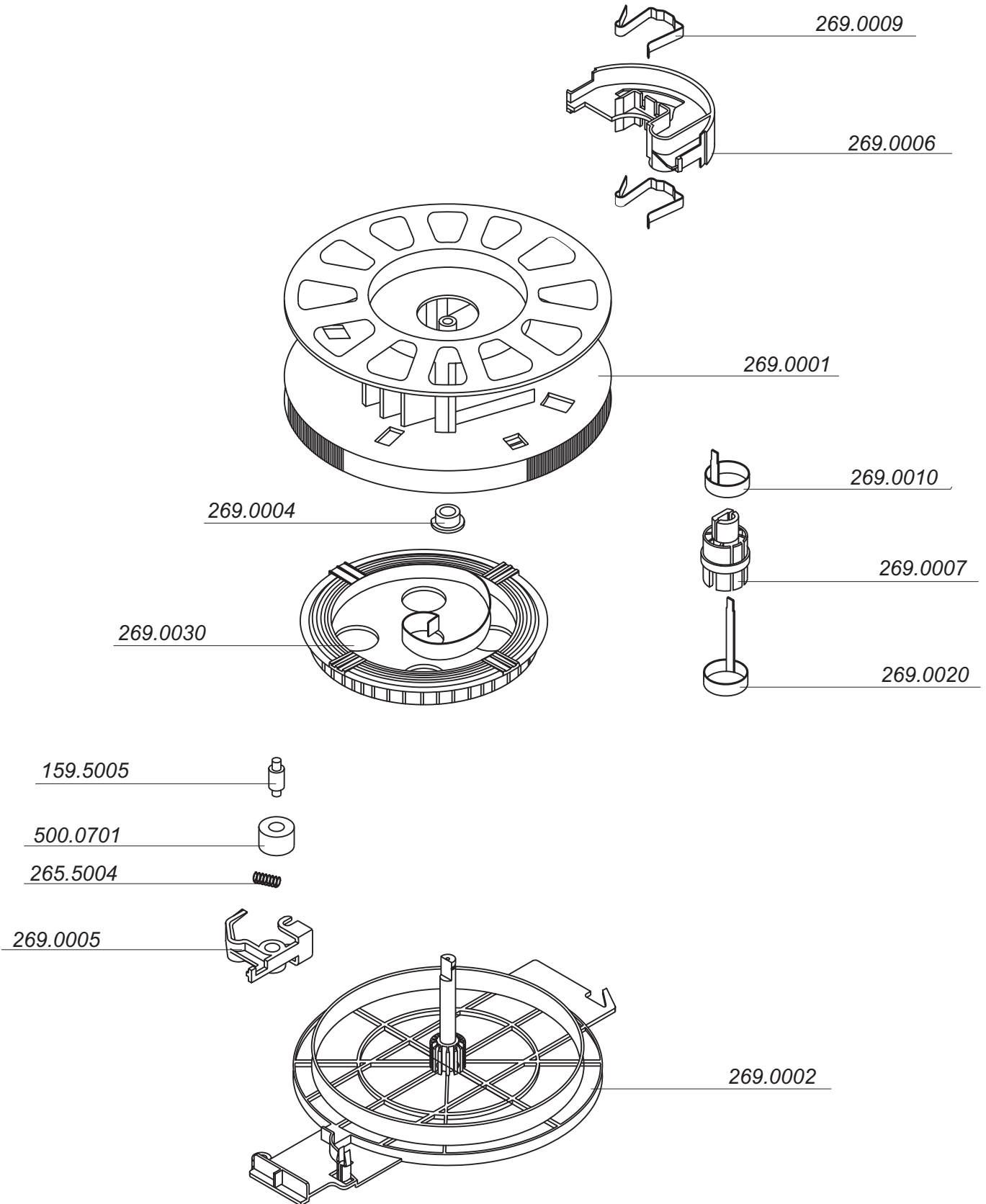

IV VACUUM CLEANER ACCESSORIES

ZELMER TYPE 1500.0.F08S

(RED "FERRARI")

ZELMER HUNGARY

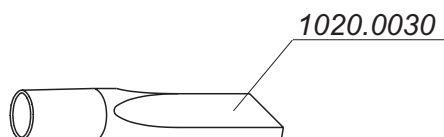
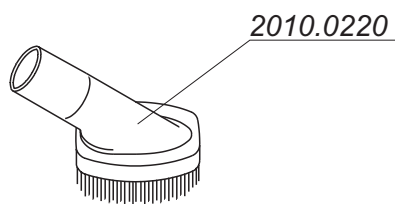
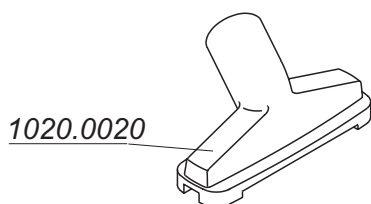
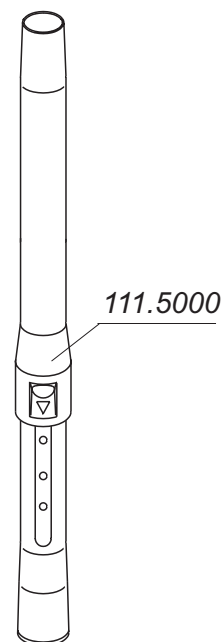
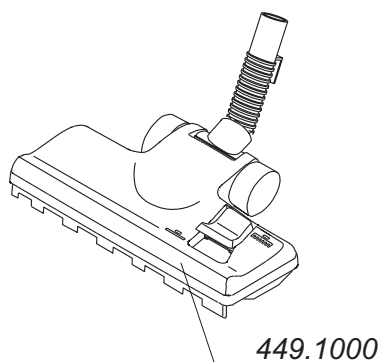
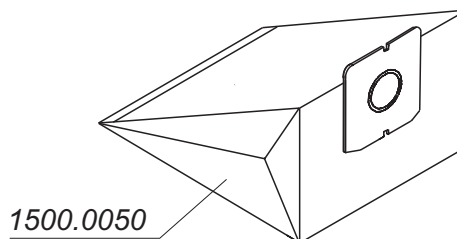
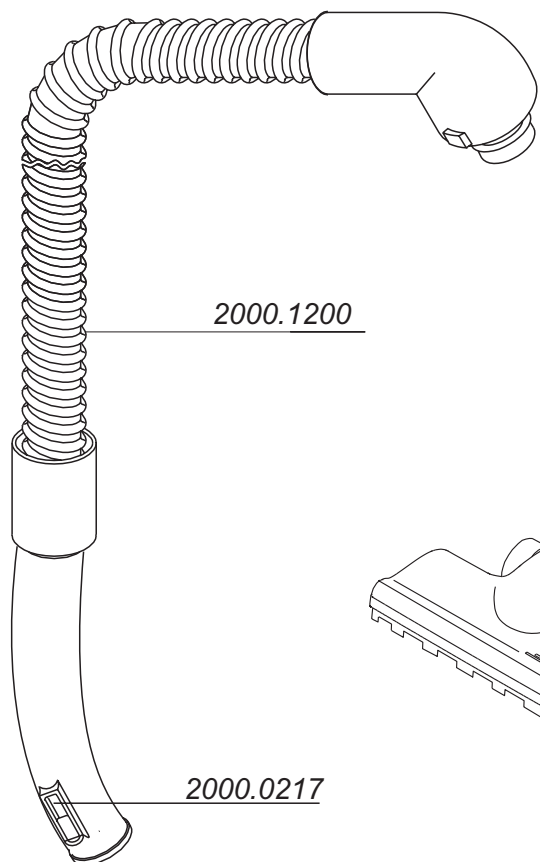

V ELECTRICAL DIAGRAM OF THE VACUUM CLEANER ZELMER TYPE 1500.0.F08S ZELMER HUNGARY

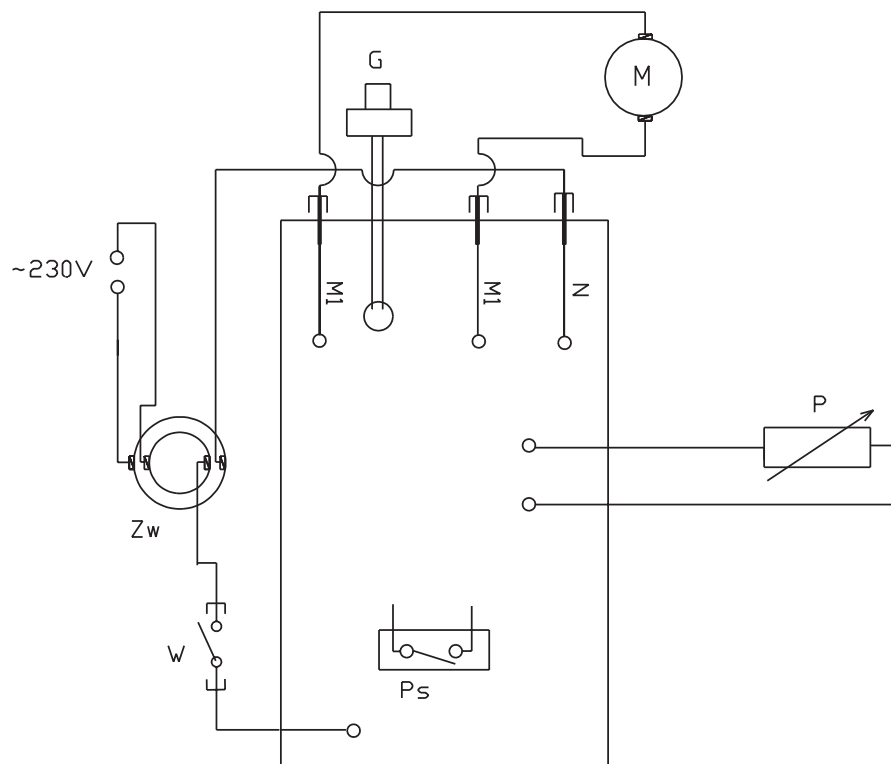

Z_w - CORD WINDER
M - MOTOR
W - MAIN SWICH
G - ELECTROBRUSH - SOCKET
P - POTENTIOMETER
P_s - PARKSYSTEM

