

VACUUM CLEANER ZELMER TYPE 1500.0.F08S (KÉK OPAL) (SÁRGA OPAL) ZELMER HUNGARY

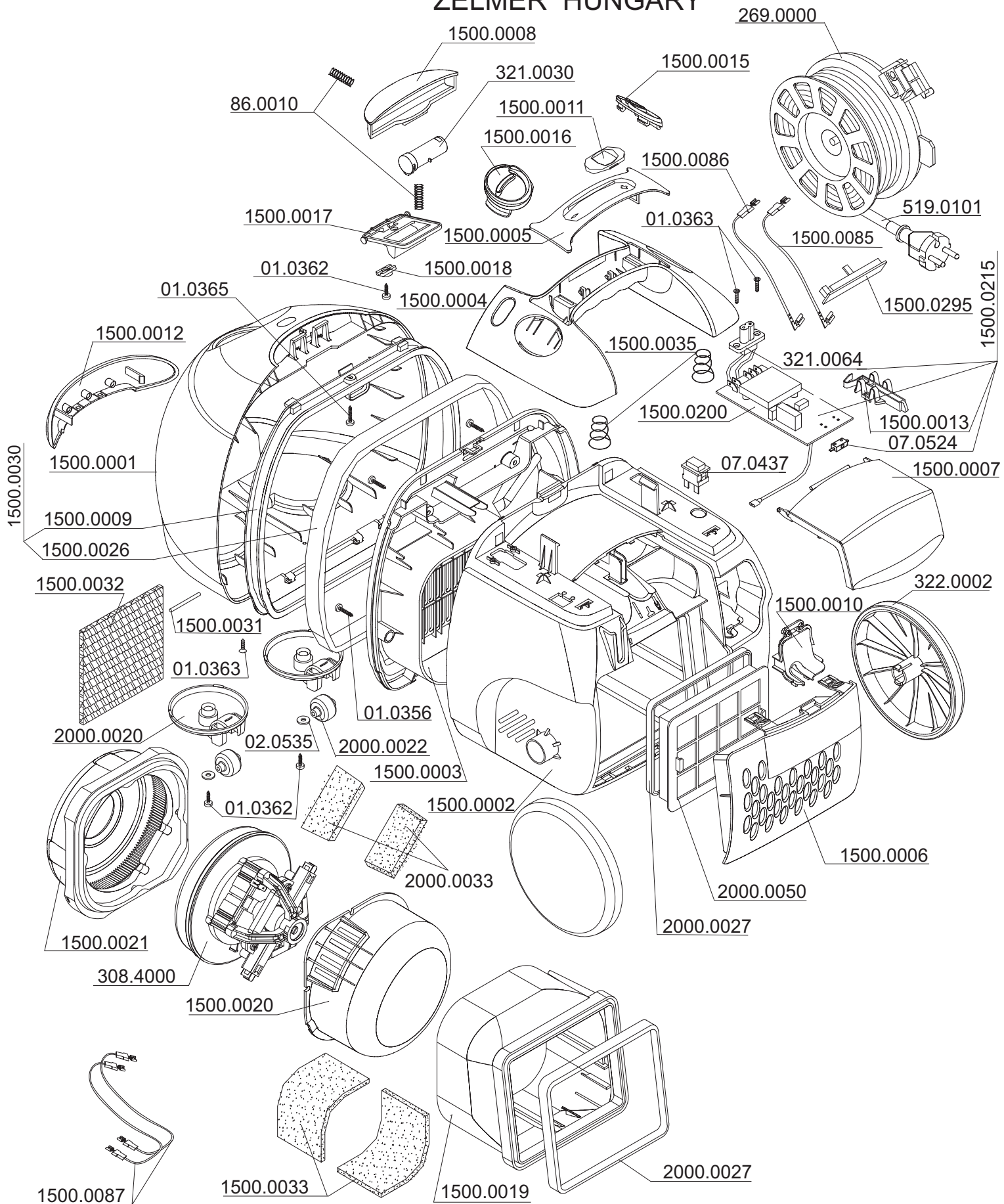

SUCTION UNIT TYPE 308.4000

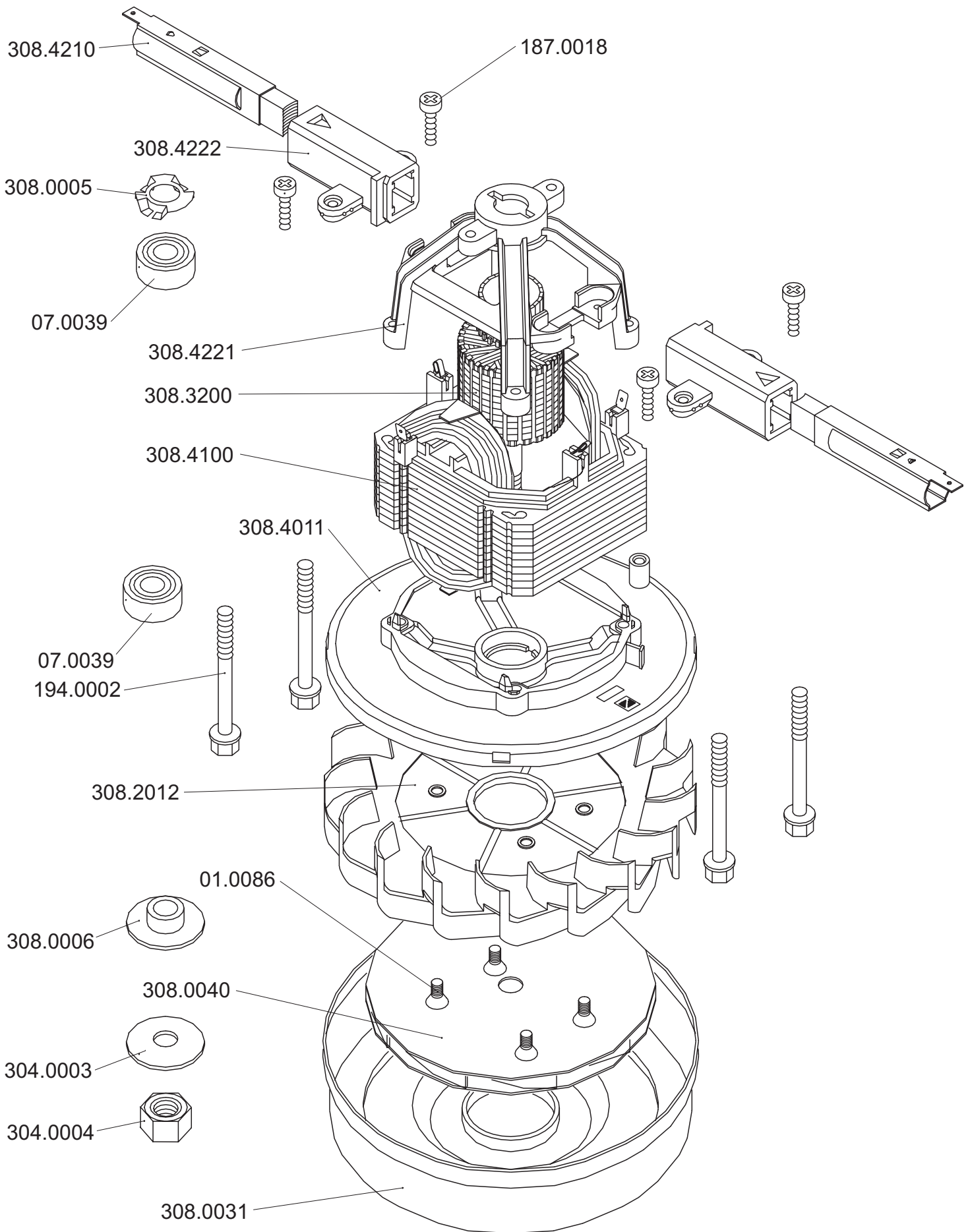

III CORD WINDER 269.0000

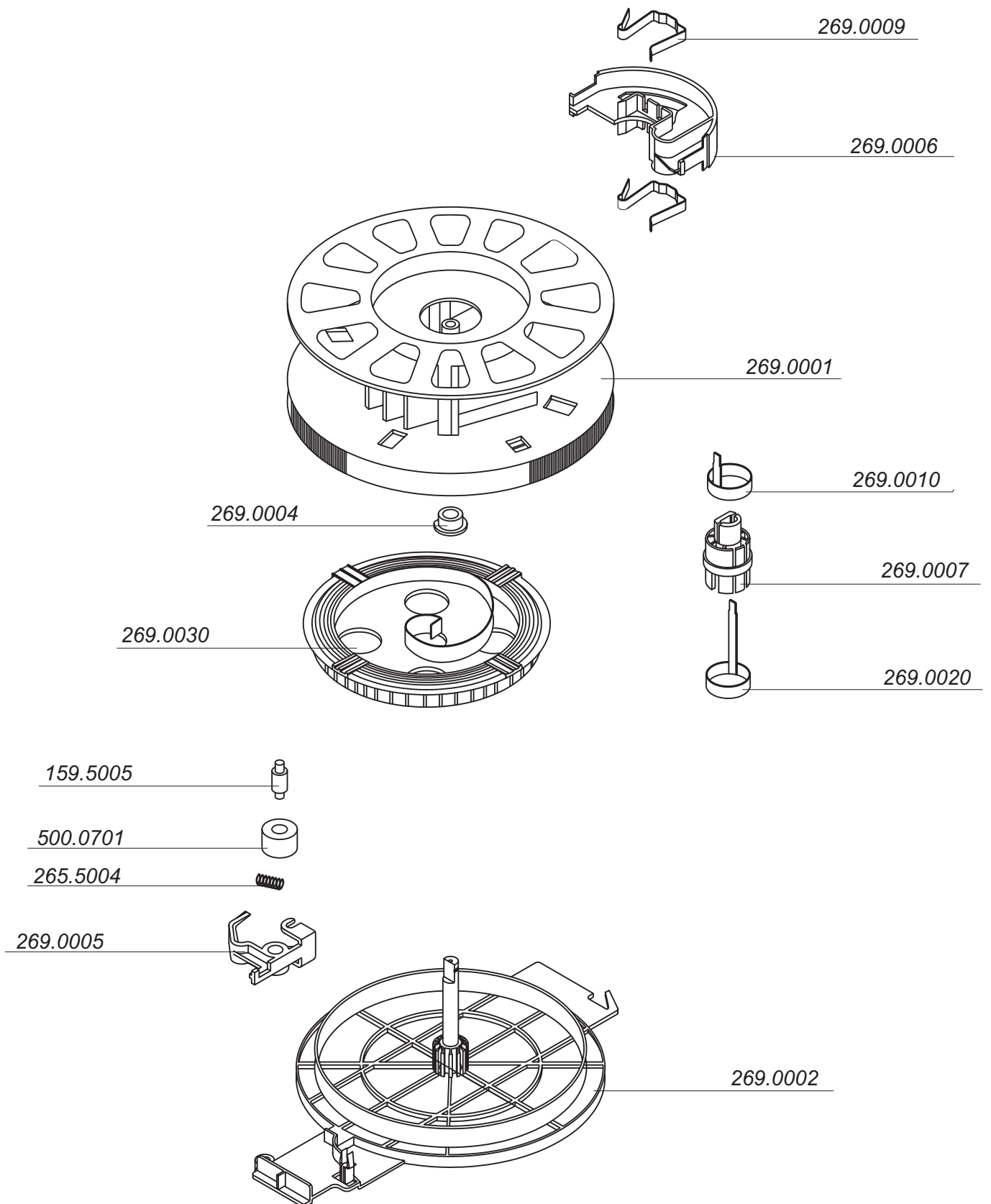

IV VACUUM CLEANER ACCESSORIES
ZELMER TYPE 1500.0.F08S
(KÉK OPAL)
(SÁRGA OPAL)
ZELMER HUNGARY

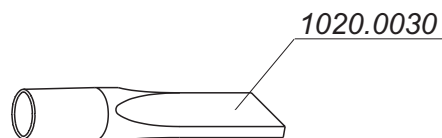
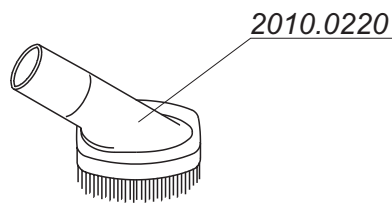
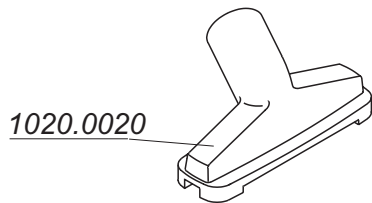
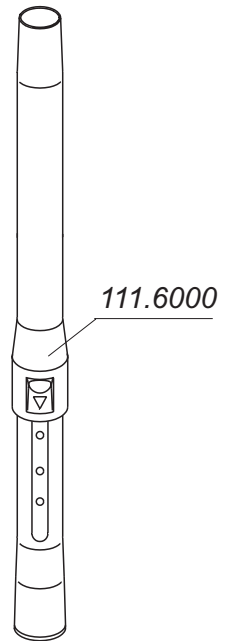
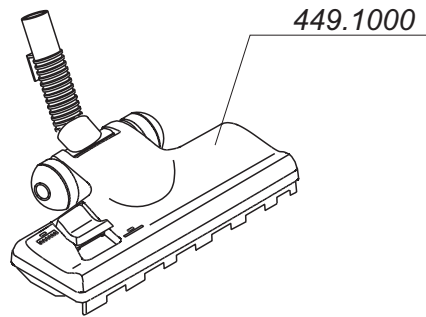
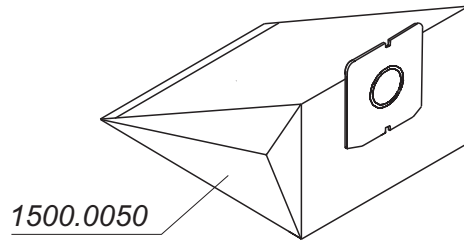
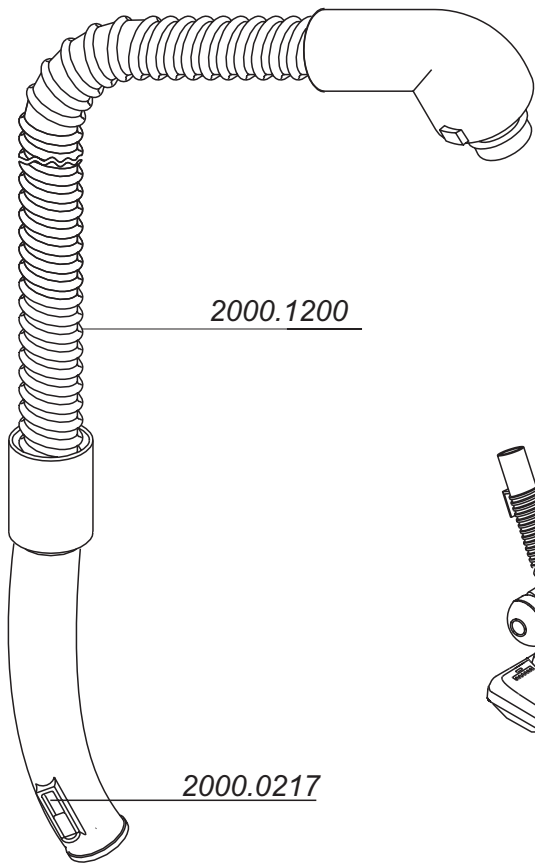

V ELECTRICAL DIAGRAM OF THE VACUUM CLEANER ZELMER TYPE 1500.0.F08S ZELMER HUNGARY

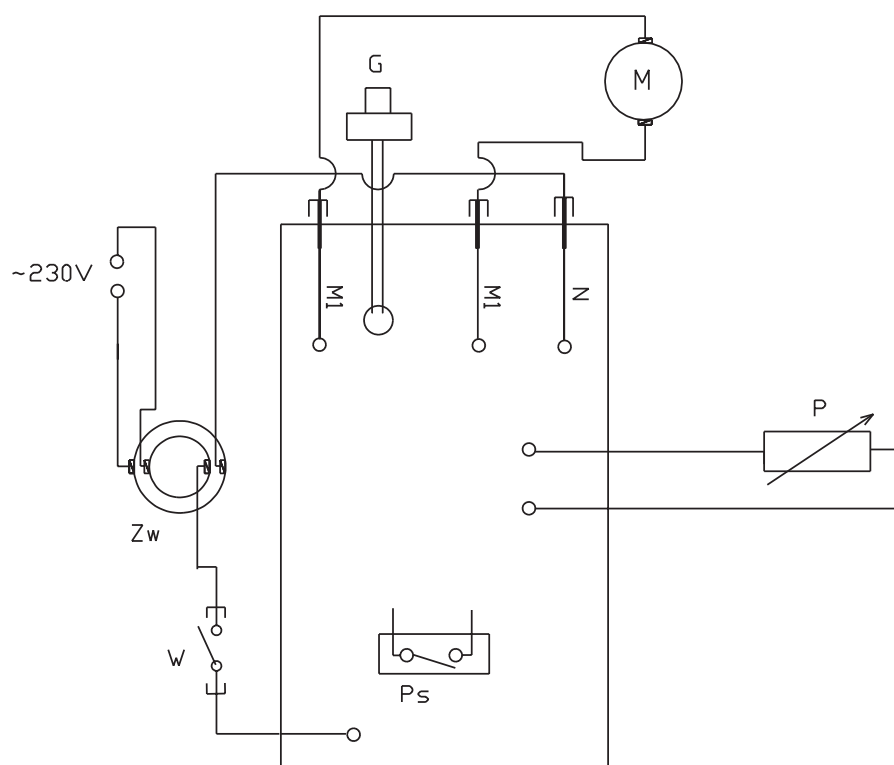

- Zw - CORD WINDER
- M - MOTOR
- W - MAIN SWICH
- G - ELECTROBRUSH - SOCKET
- P - POTENTIOMETER
- Ps - PARKSYSTEM

VI DISMANTLE OF VACUUM CLEANER ZELMER TYPE 1500

