

# VACUUM CLEANER ZELMER TYPE 1500.0.F08S (GREEN RAL 6018) ZELMER HUNGARY

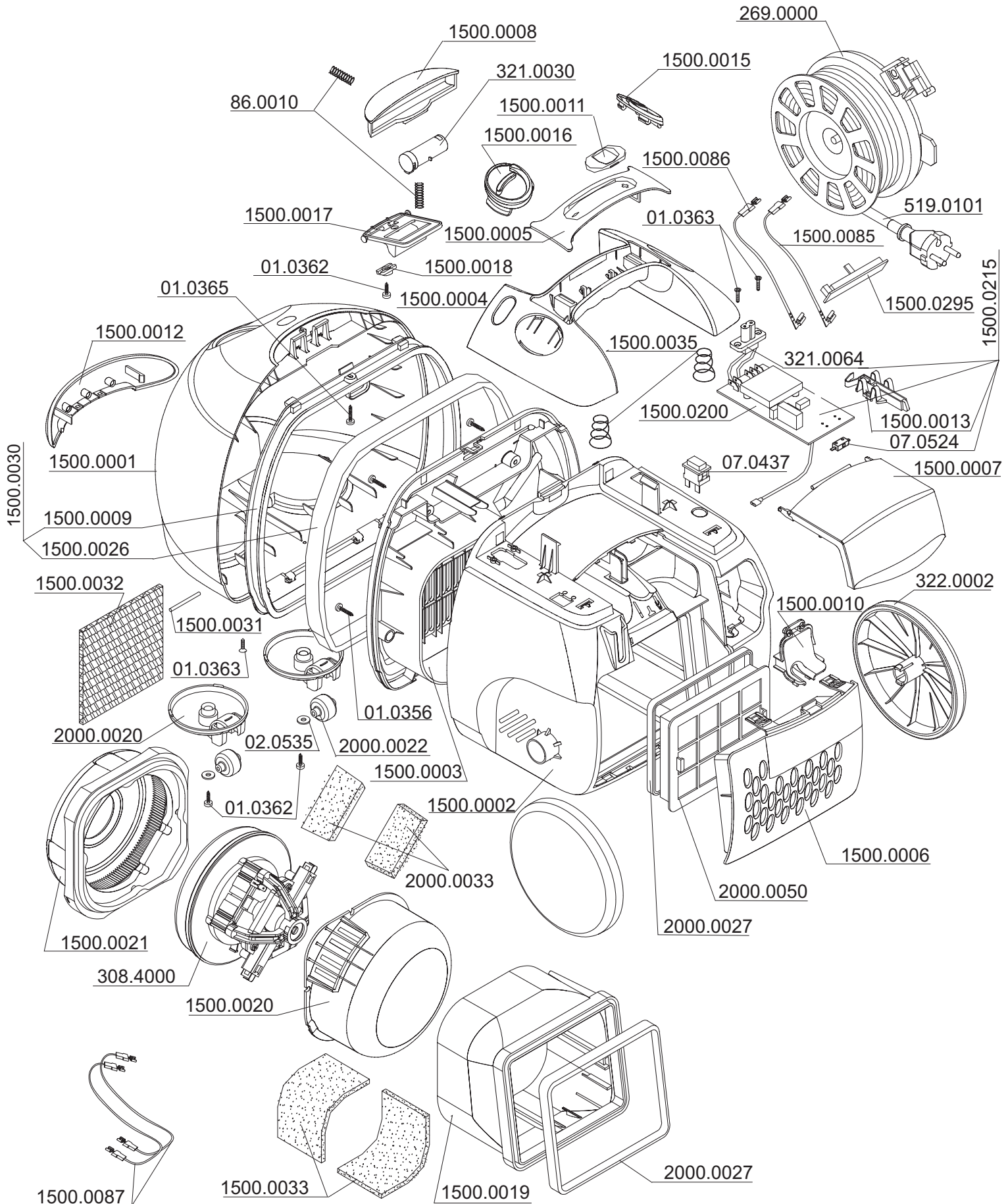

## II SUCTION UNIT TYPE 308.4000

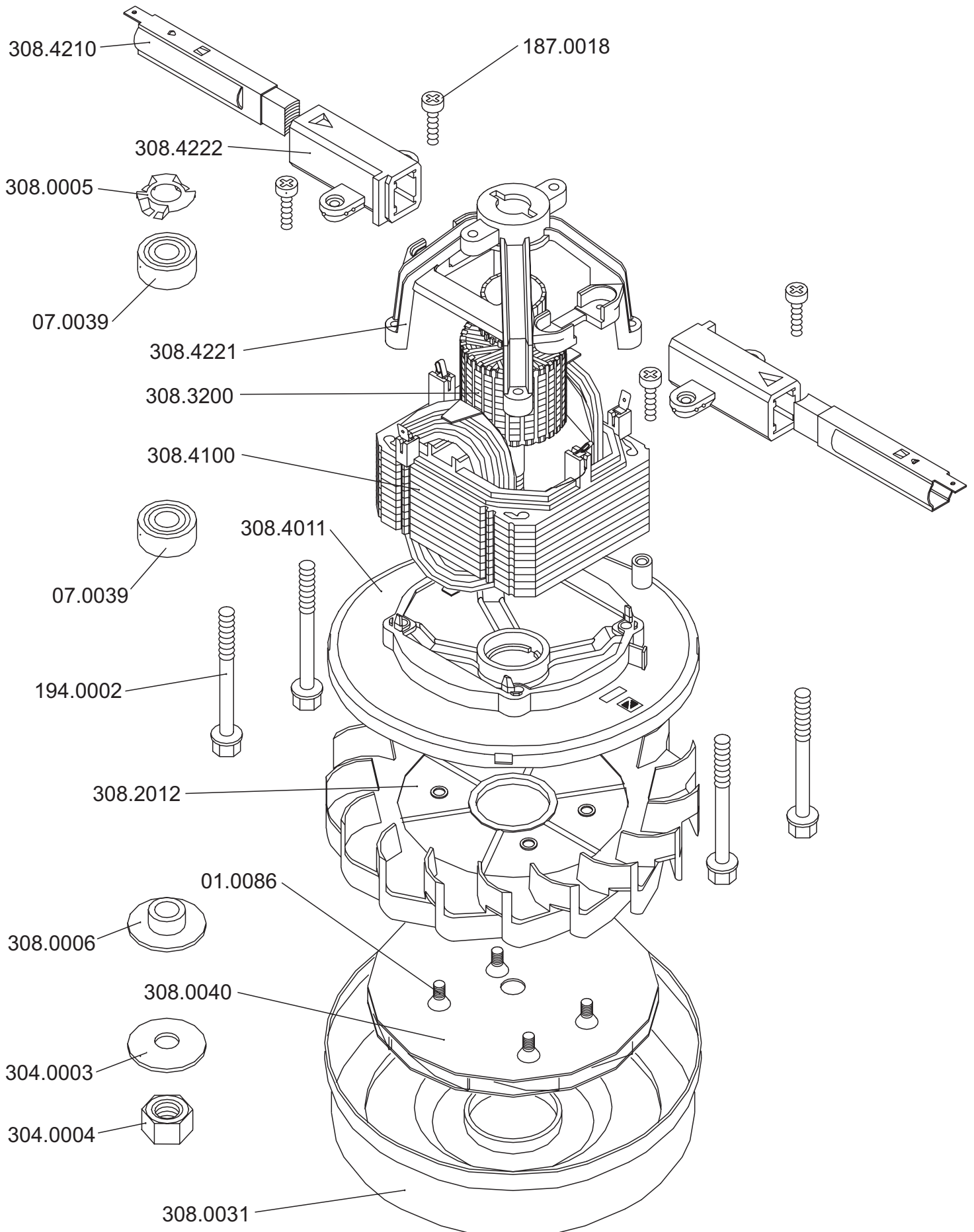

# III CORD WINDER 269.0000

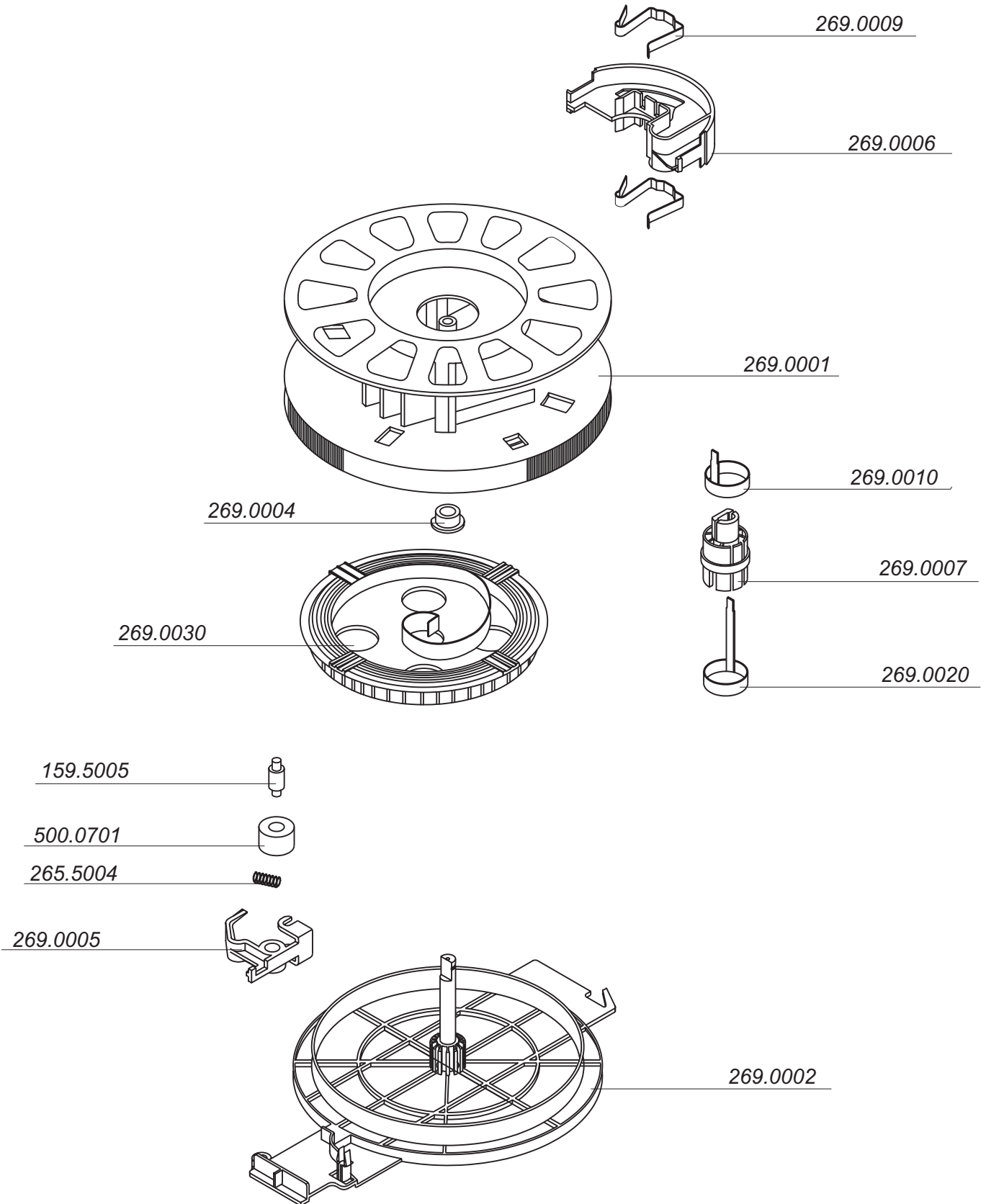

# IV VACUUM CLEANER ACCESSORIES

## ZELMER TYPE 1500.0.F08S (YELLOW RAL 6018) ZELMER HUNGARY

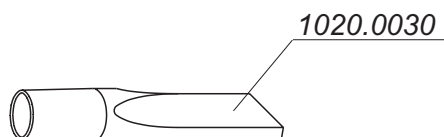
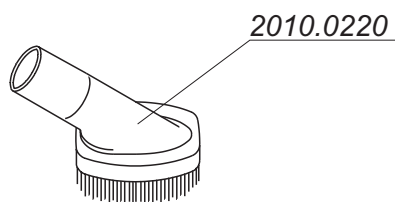
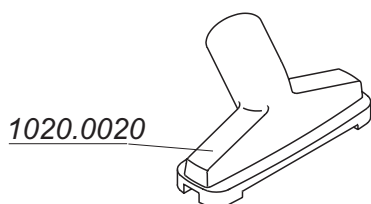
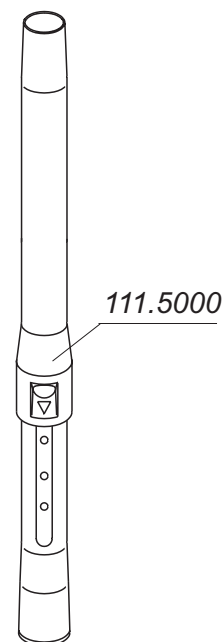
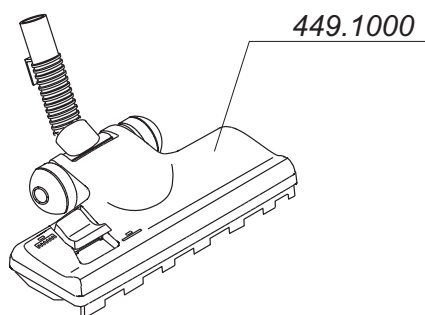
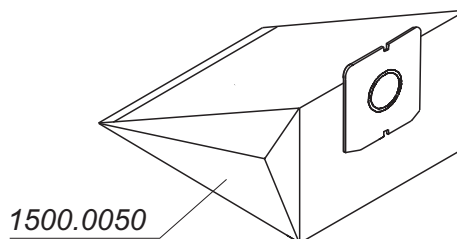
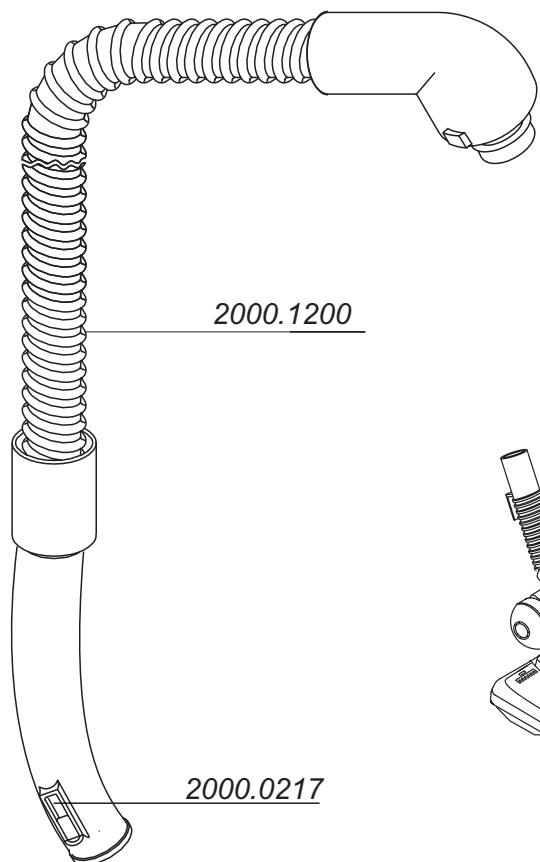

# V ELECTRICAL DIAGRAM OF THE VACUUM CLEANER ZELMER TYPE 1500.0.F08S ZELMER HUNGARY

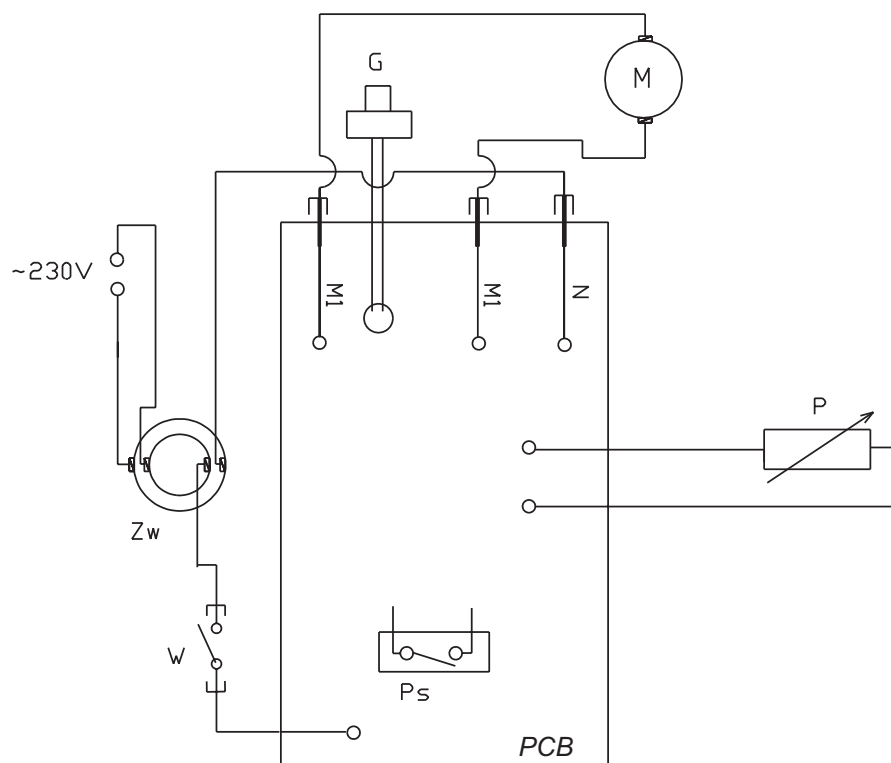

*Zw* - CORD WINDER  
*M* - MOTOR  
*W* - MAIN SWICH  
*G* - ELECTROBRUSH - SOCKET  
*P* - POTENTIOMETER  
*Ps* - PARKSYSTEM  
*PCB* - POWER CONTROL

# VI DISMANTLE OF VACUUM CLEANER ZELMER TYPE 1500

