

II SUCTION UNIT TYPE 308.2000

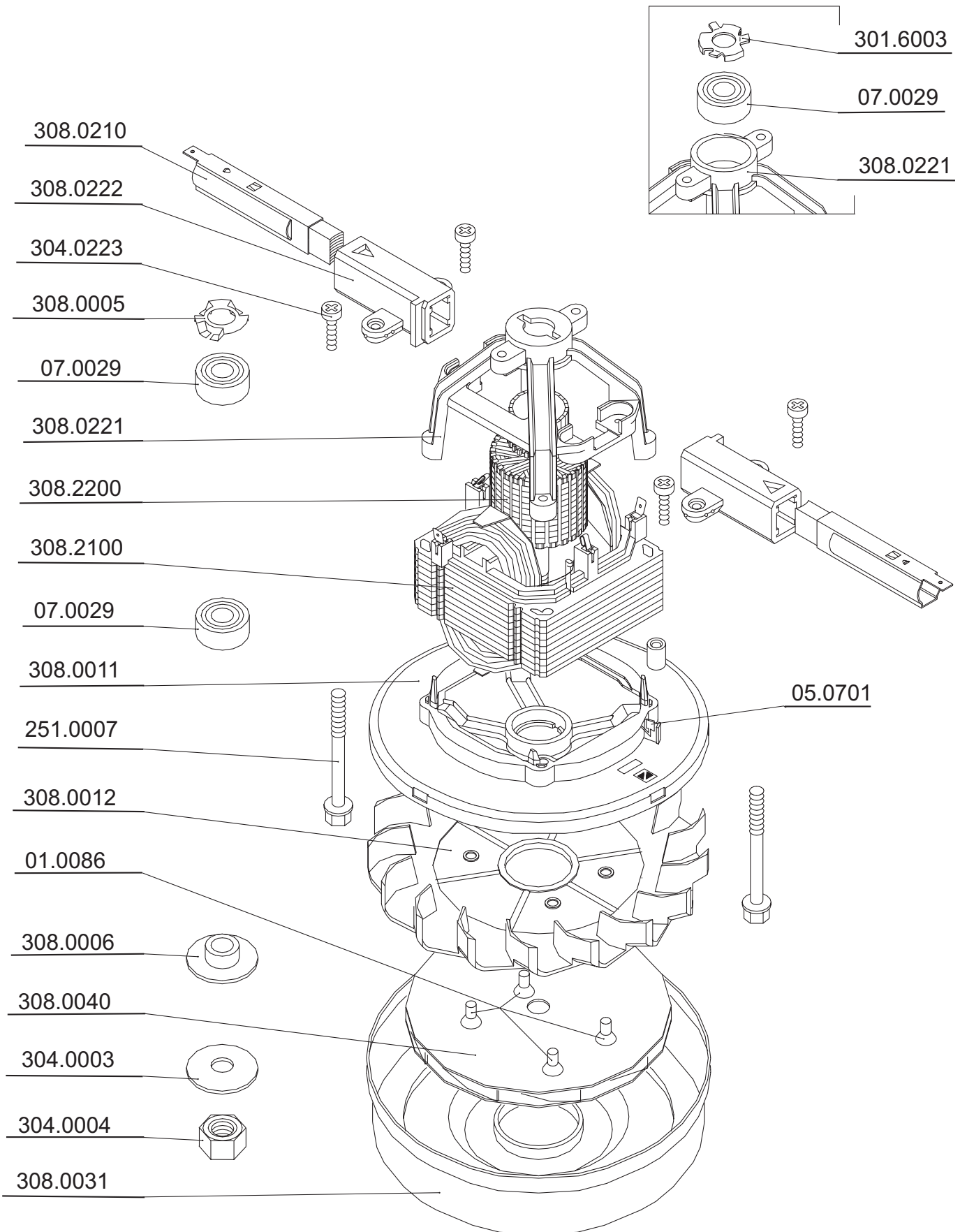

III CORD WINDER 269.0000

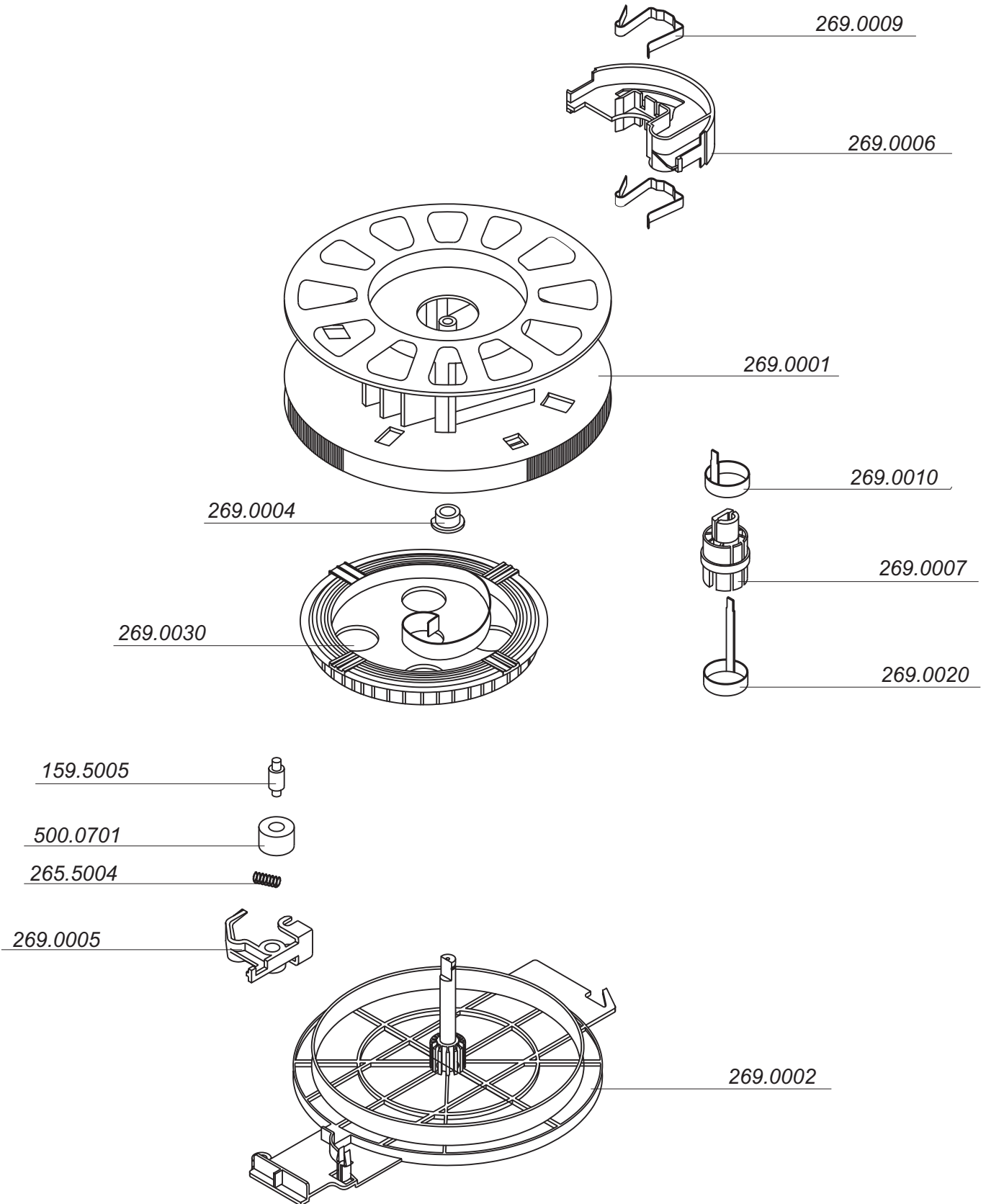

IV VACUUM CLEANER ACCESSORIES

ZELMER TYPE 1500.5.E02E (GREEN RAL 6018) ZELMER HUNGARY

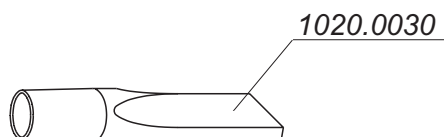
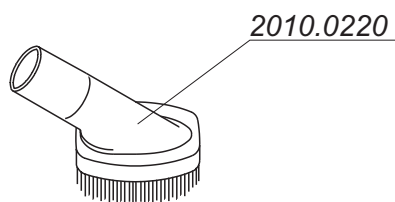
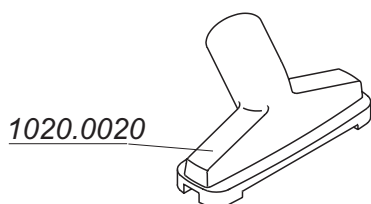
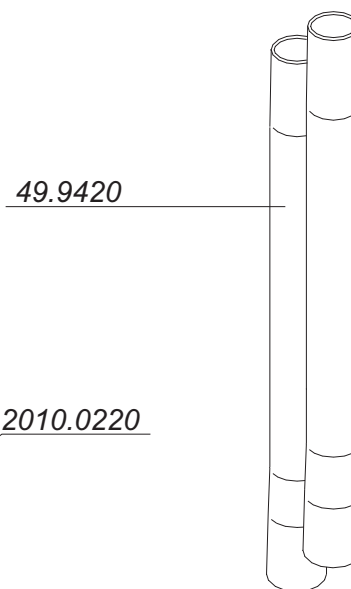
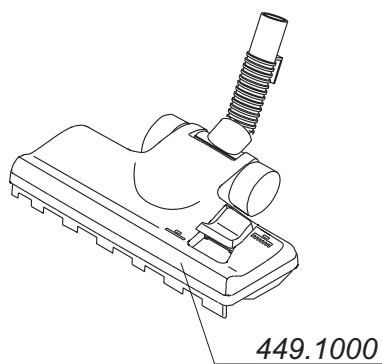
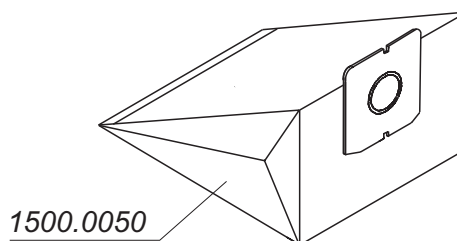
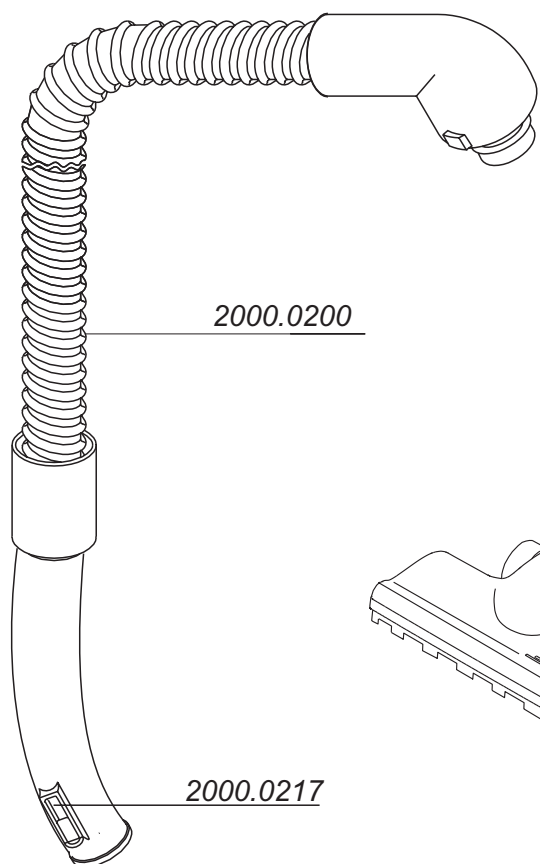

V ELECTRICAL DIAGRAM OF THE VACUUM CLEANER ZELMER TYPE 1500.5.E02E ZELMER HUNGARY

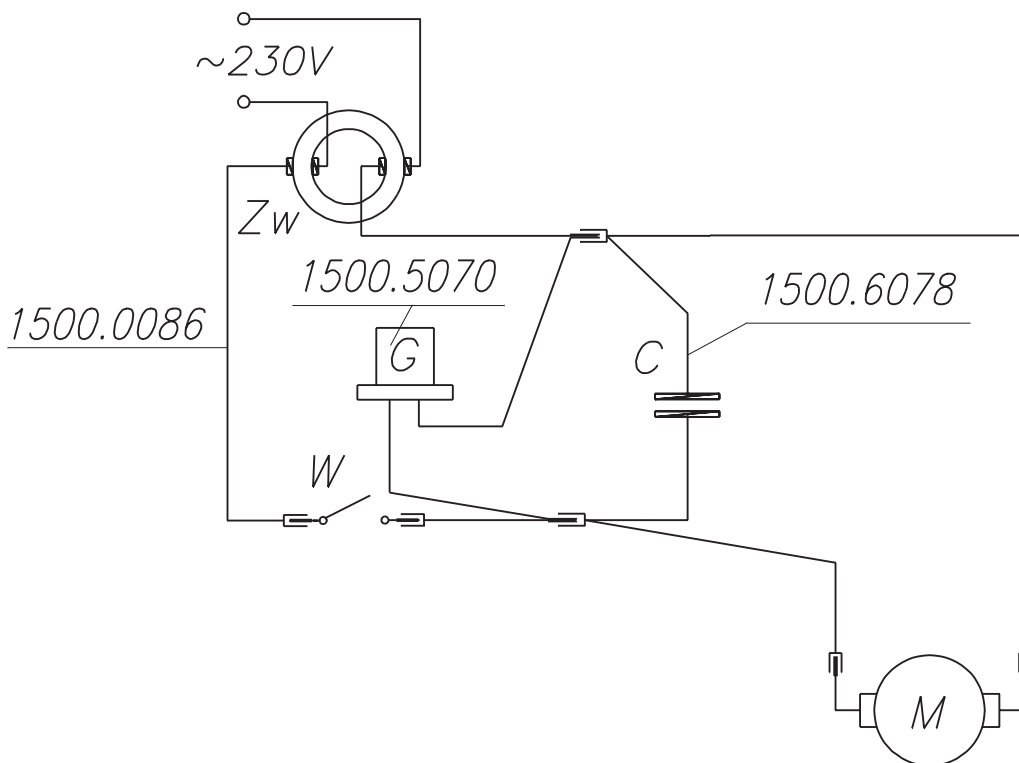

- Z - CORD WINDER
- C - CAPACITOR
- M - MOTOR
- W - MAIN SWICH
- G - ELECTROBRUSH - SOCKET

VI DISMANTLE OF VACUUM CLEANER ZELMER TYPE 1500

