

VACUUM CLEANER ZELMER TYPE 1500.6.E02E (BLUE RAL 5012) ZELMER HUNGARY

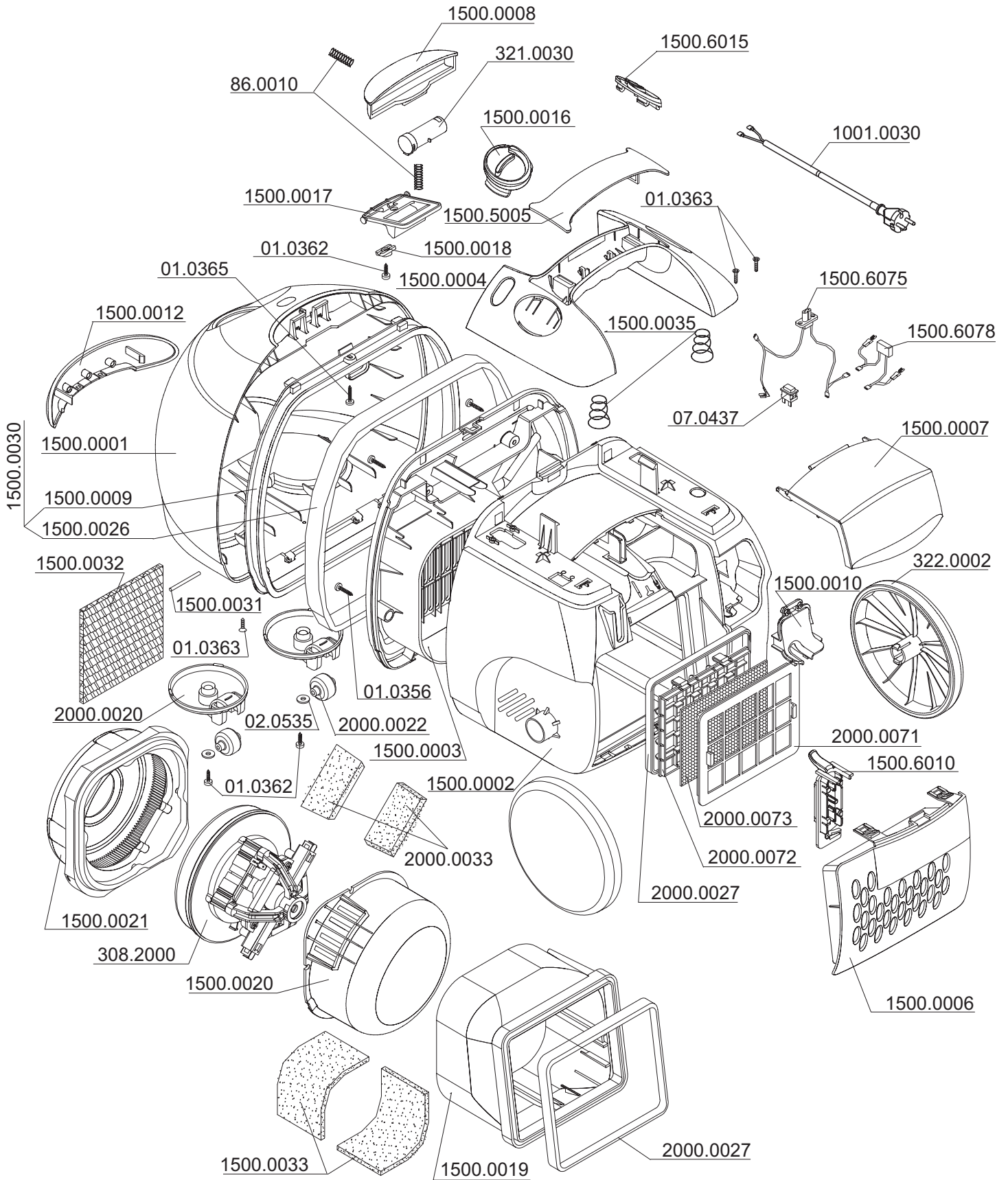

II SUCTION UNIT TYPE 308.2000

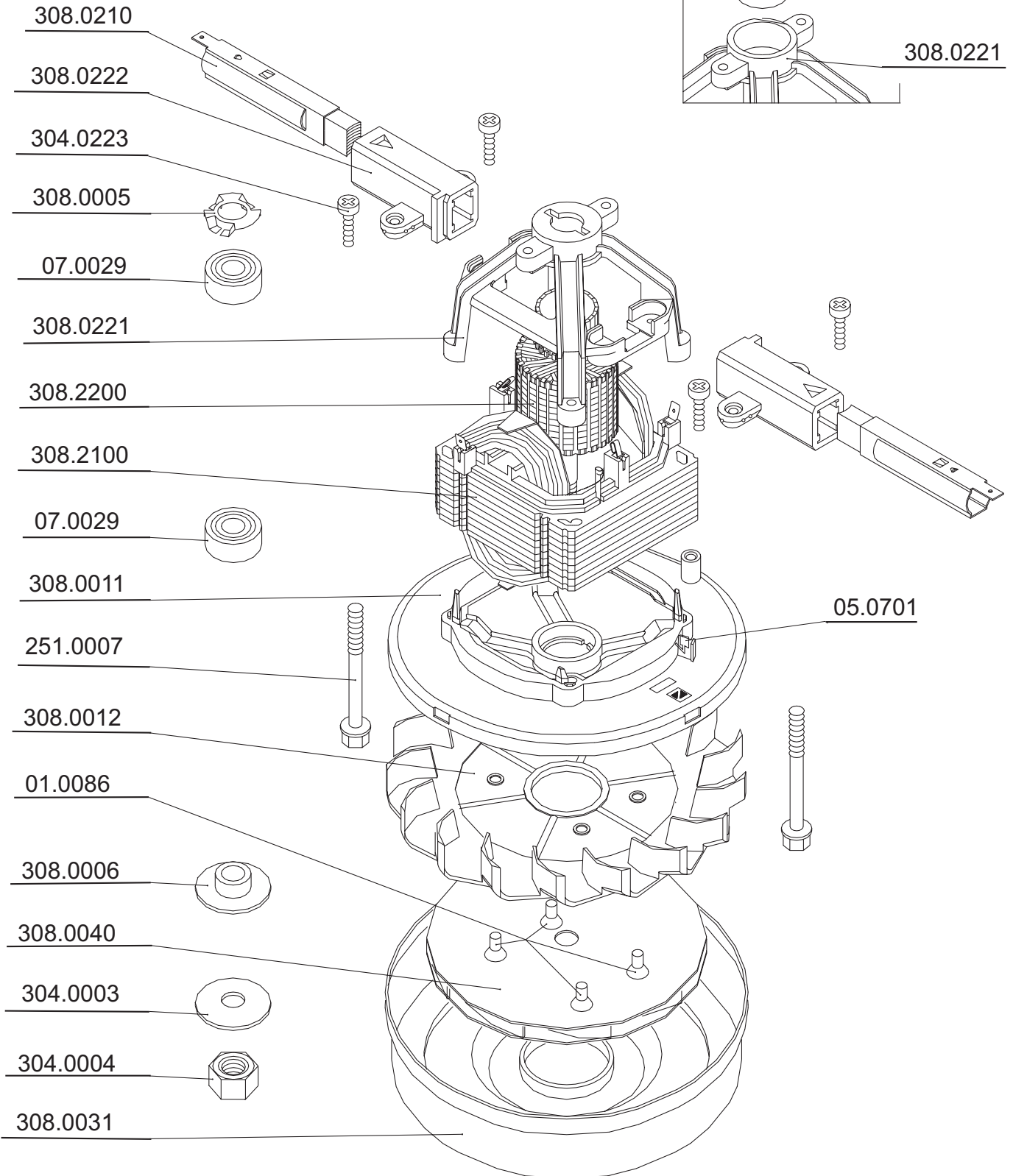
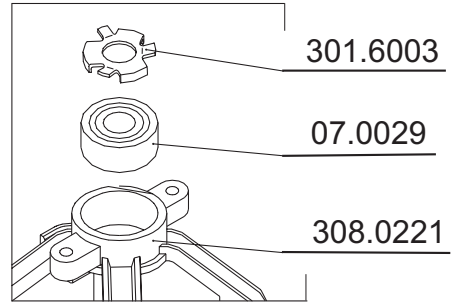

IV VACUUM CLEANER ACCESSORIES

ZELMER TYPE 1500.6.E02E (BLUE RAL 5012) ZELMER HUNGARY

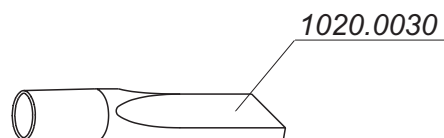
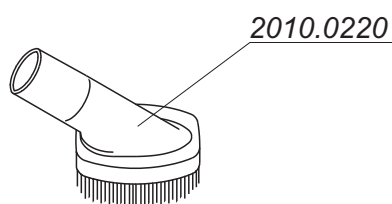
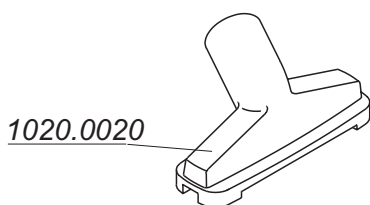
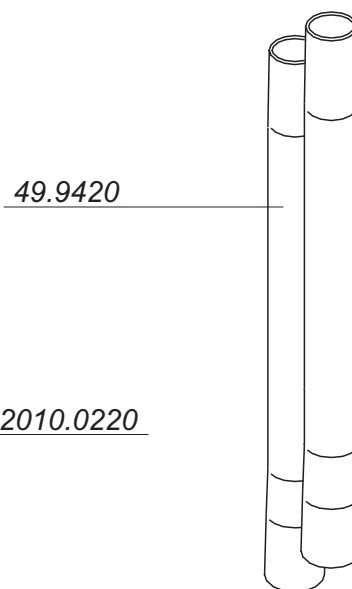
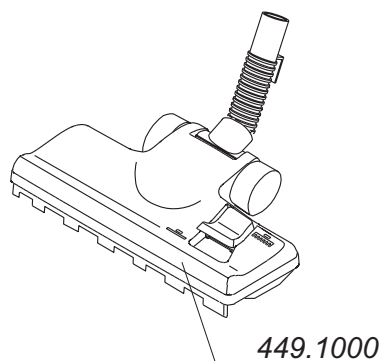
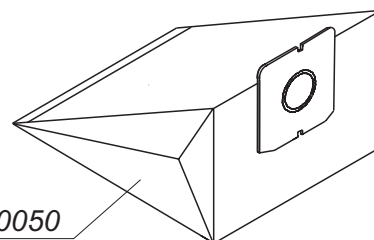
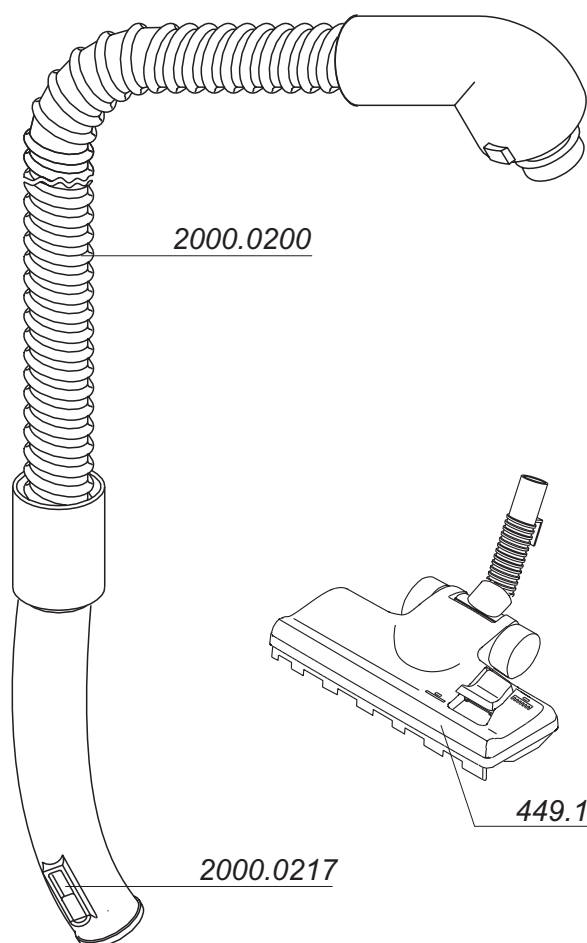

V ELECTRICAL DIAGRAM OF THE VACUUM CLEANER ZELMER TYPE 1500.6.E02E ZELMER HUNGARY

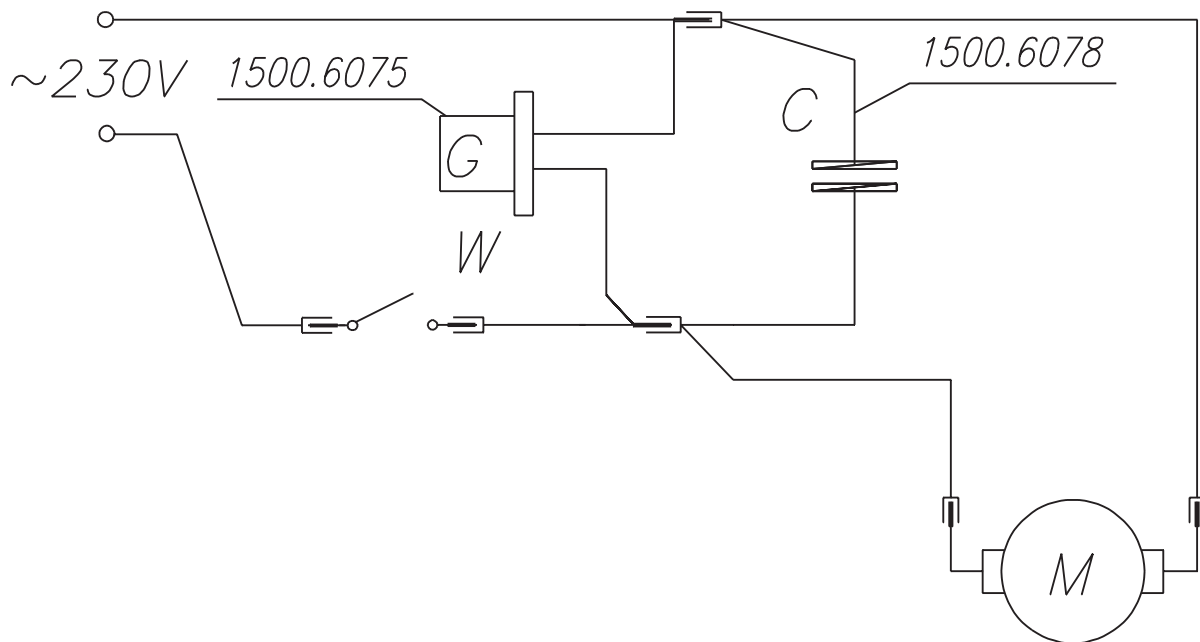

- M - MOTOR
- W - MAIN SWICH
- G - ELECTROBRUSH - SOCKET
- C - CAPACITOR

VI DISMANTLE OF VACUUM CLEANER ZELMER TYPE 1500

