

I VACUUM CLEANER

ZELMER TYPE 2000.0.B04S (DARK-BLUE RAL 5022)

ZELMER HUNGARY

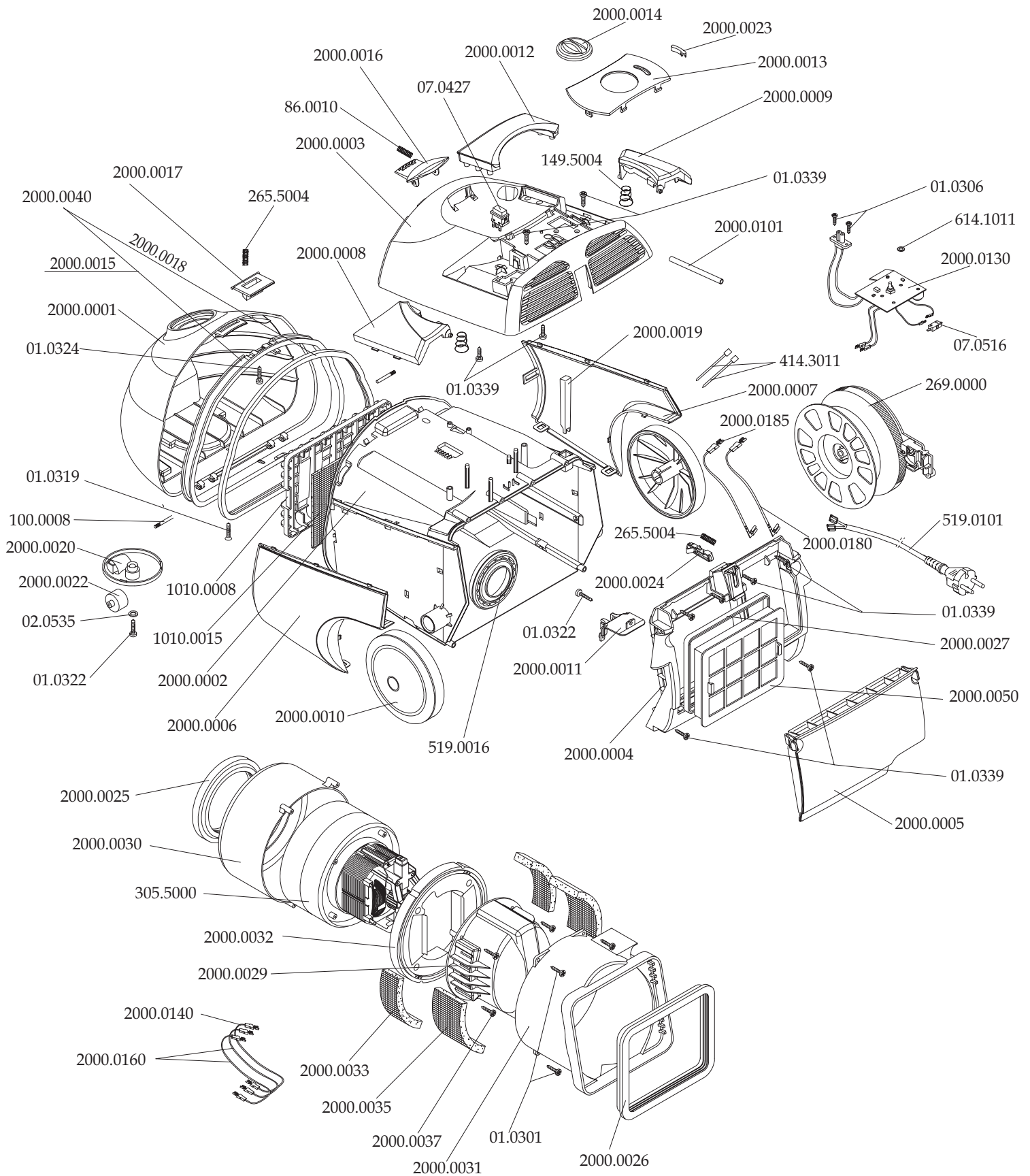

II SUCTION UNIT 305.5000

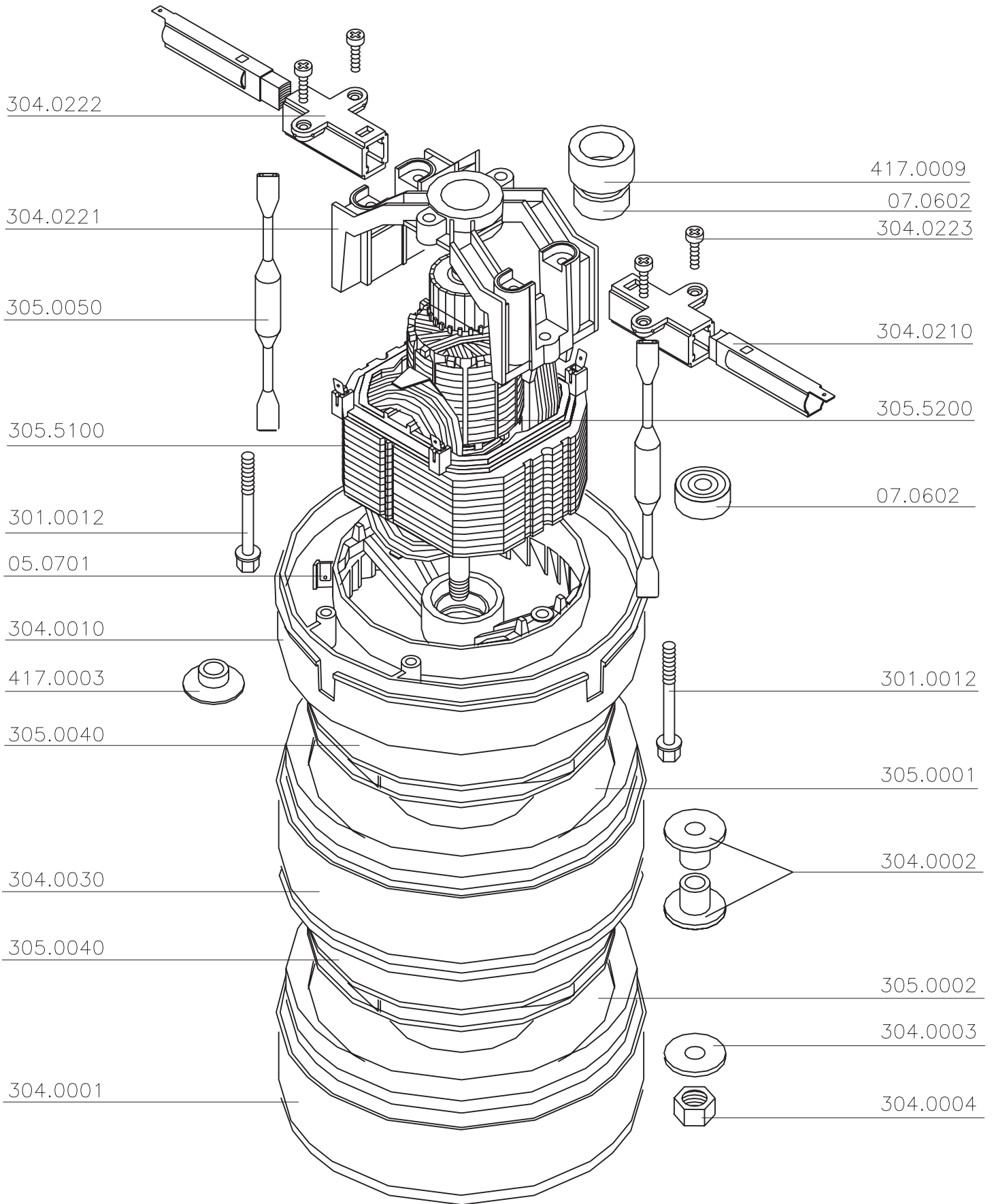

III CORD WINDER 269.0000

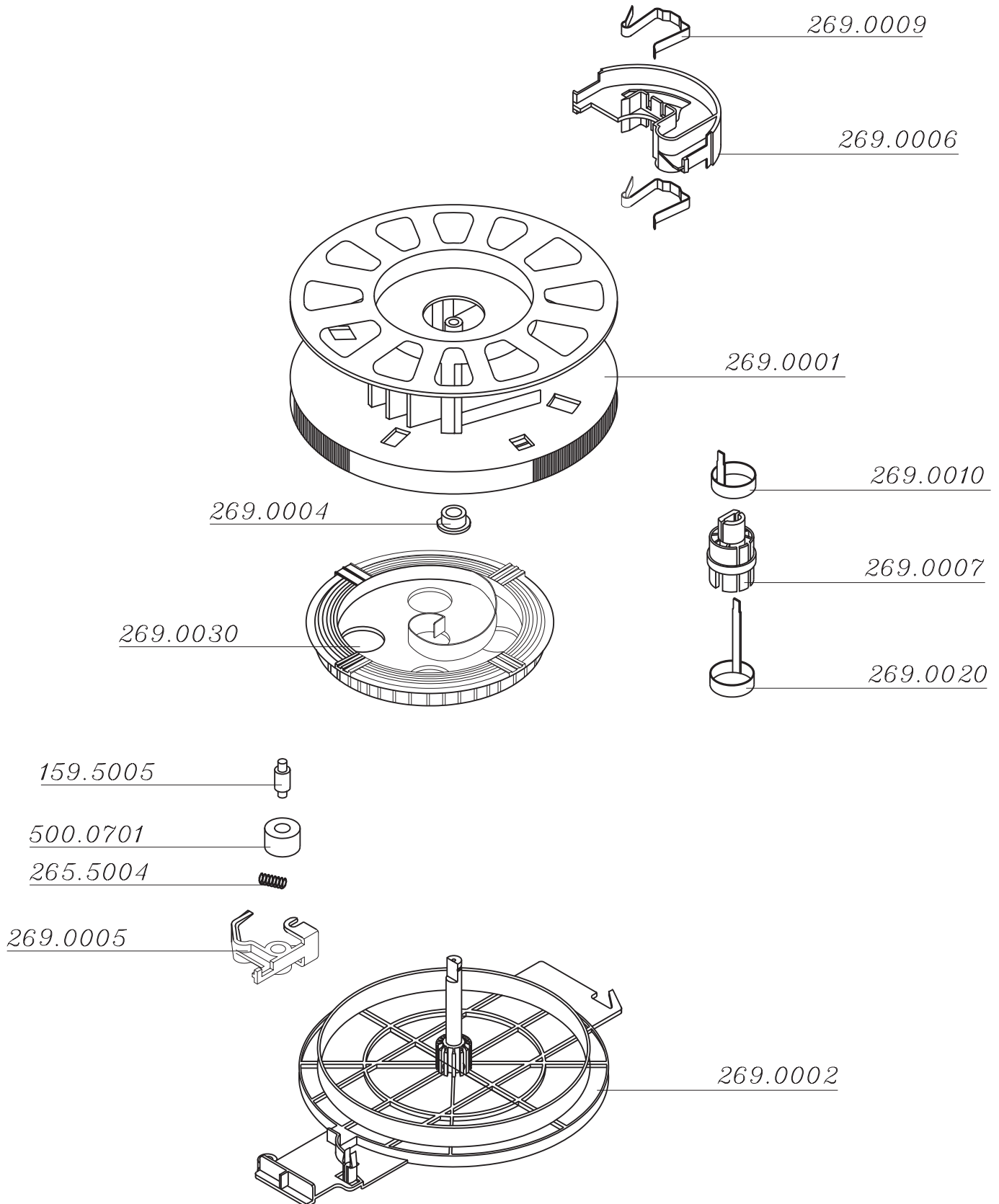

IV VACUUM CLEANER ACCESSORIES
TYPE ZELMER 2000.0.B04S (DARK-BLUE RAL 5022)
ZELMER HUNGARY

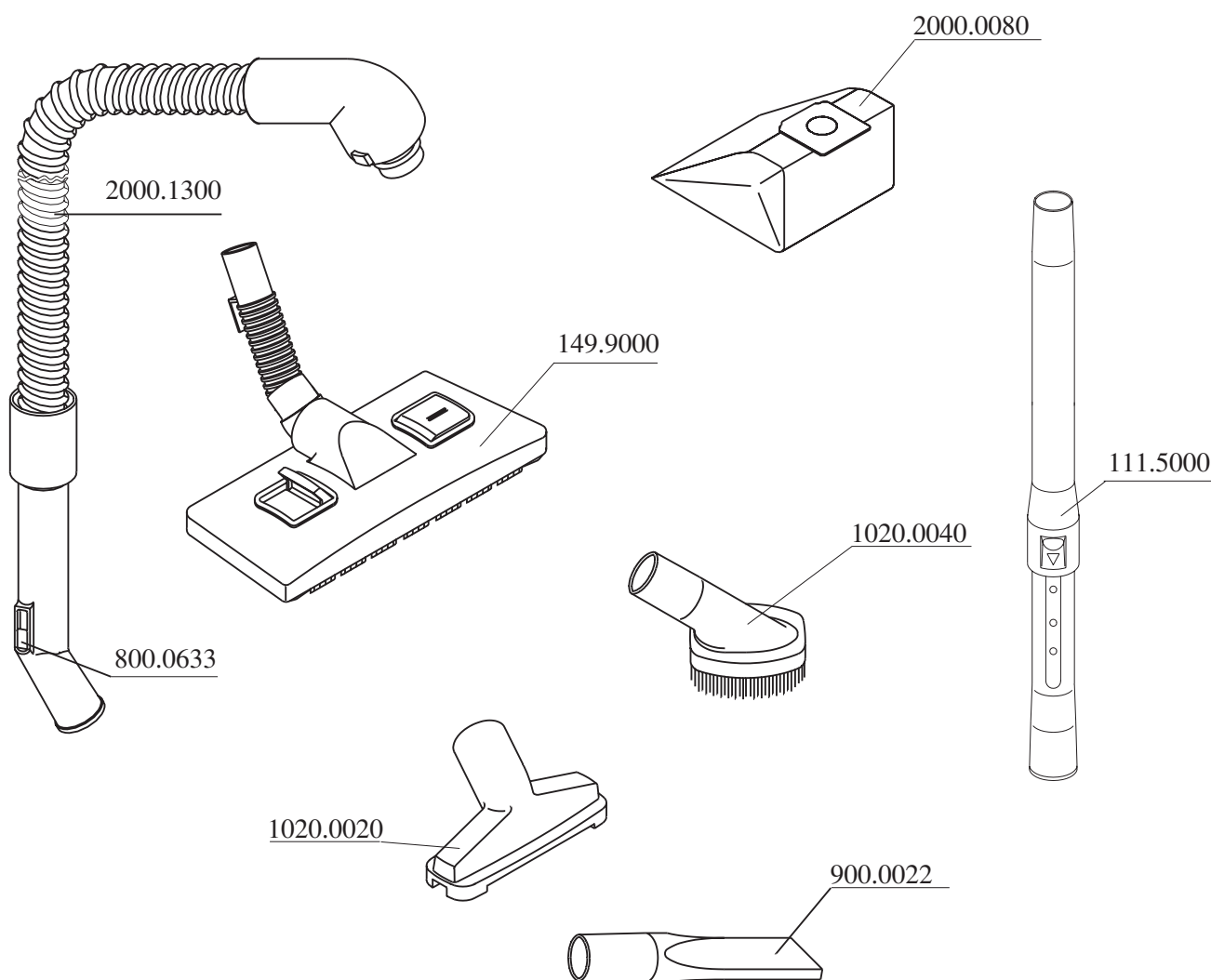

V ELECTRICAL DIAGRAM OF THE VACUUM CLEANER TYPE ZELMER 2000.0.B04S ZELMER HUNGARY

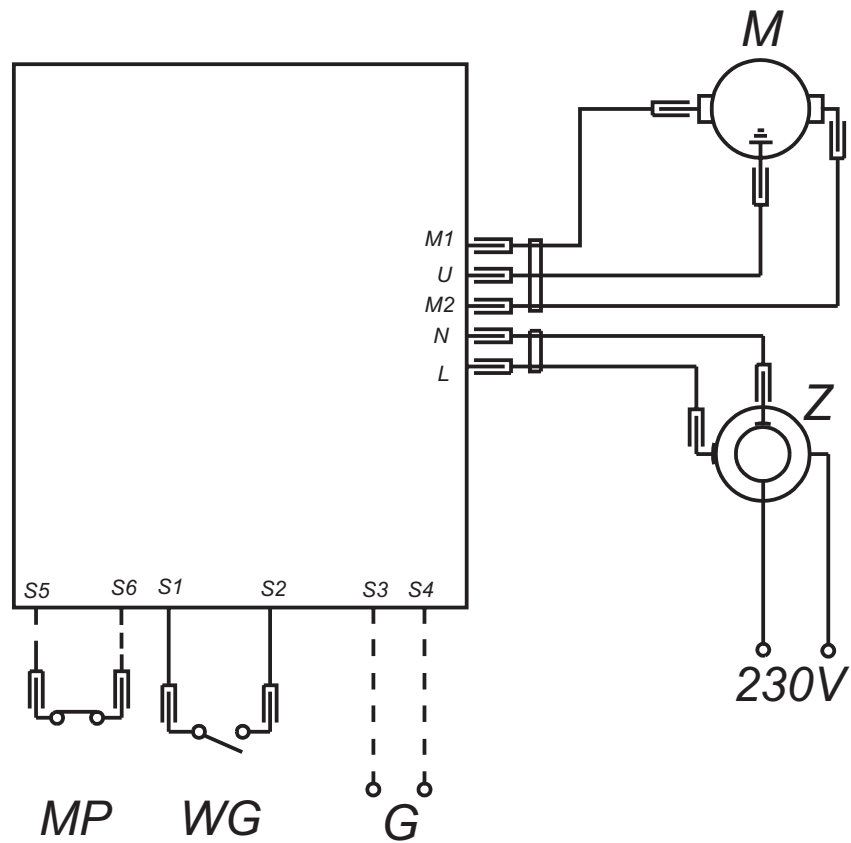

- M -suction unit
- MP -parksystem microswitch
- WG -main switch
- Z -cord winder
- G - electrobrush - socket