

III CORD WINDER 269.0000

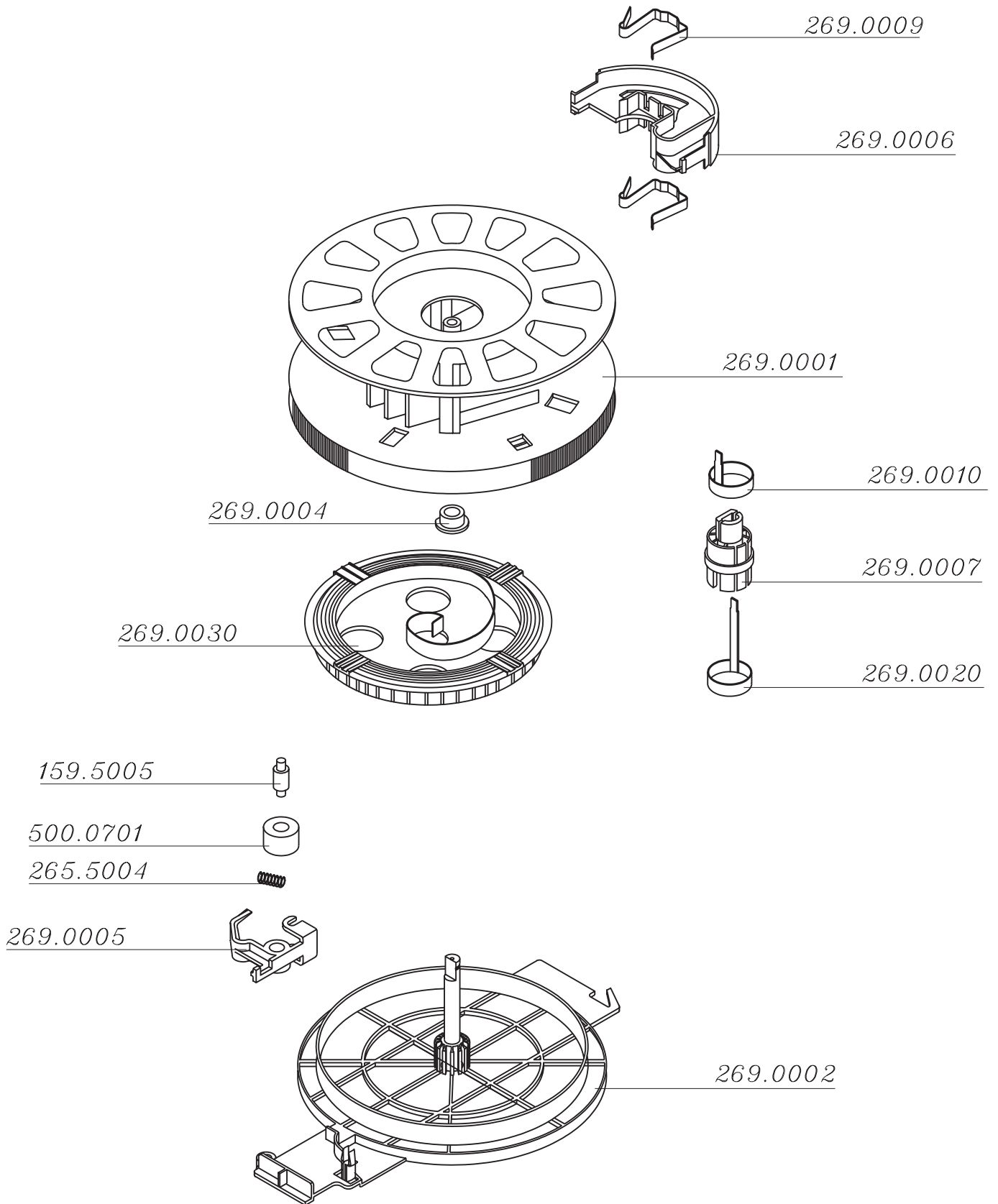

IV VACUUM CLEANER ACCESSORIES
ZELMER TYPE 2010.3.B04S (RED METALLIC)
ZELMER HUNGARY

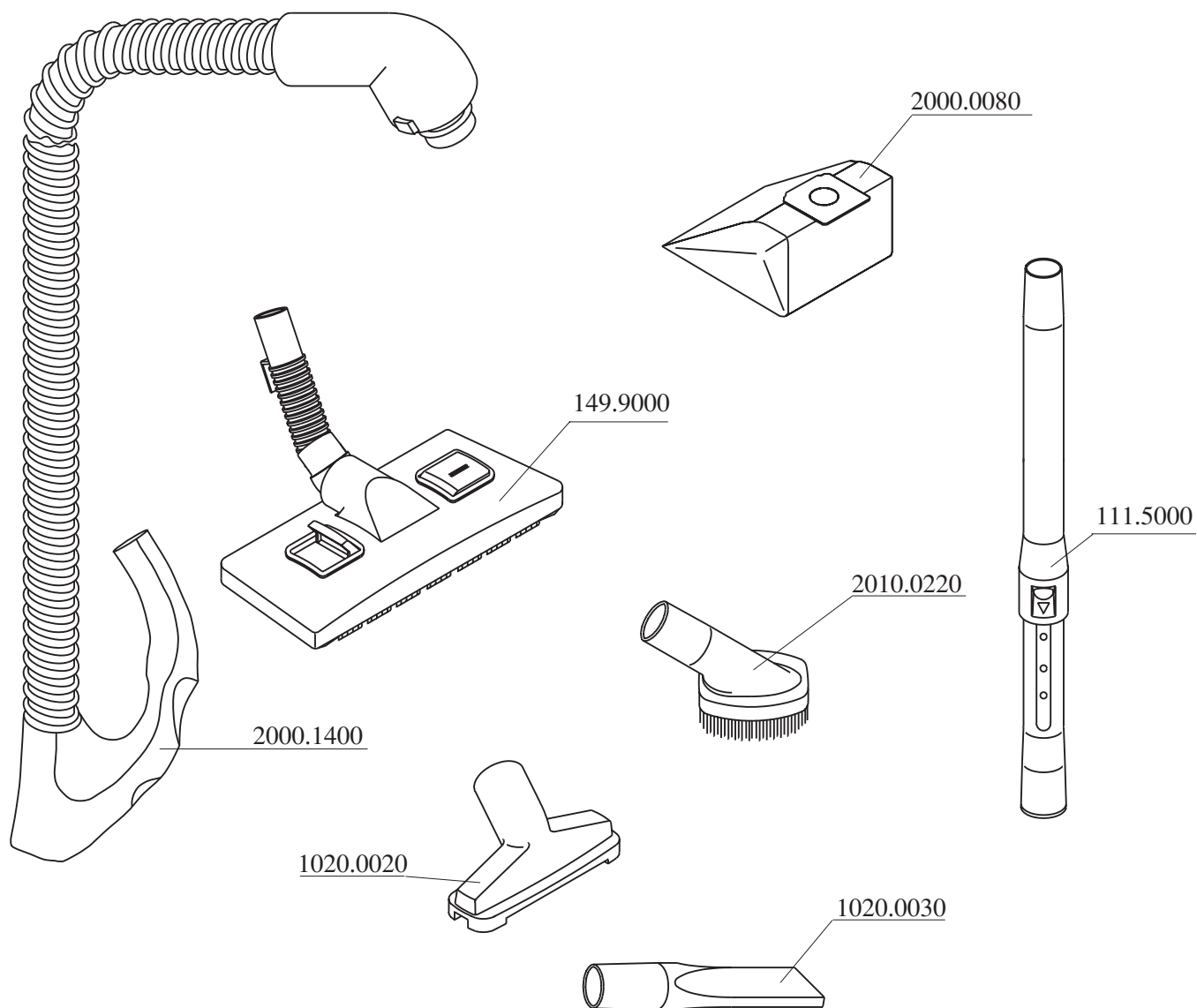

V ELECTRICAL DIAGRAM OF THE VACUUM CLEANER ZELMER TYPE 2010.3.B04S (RED METALLIC) ZELMER HUNGARY

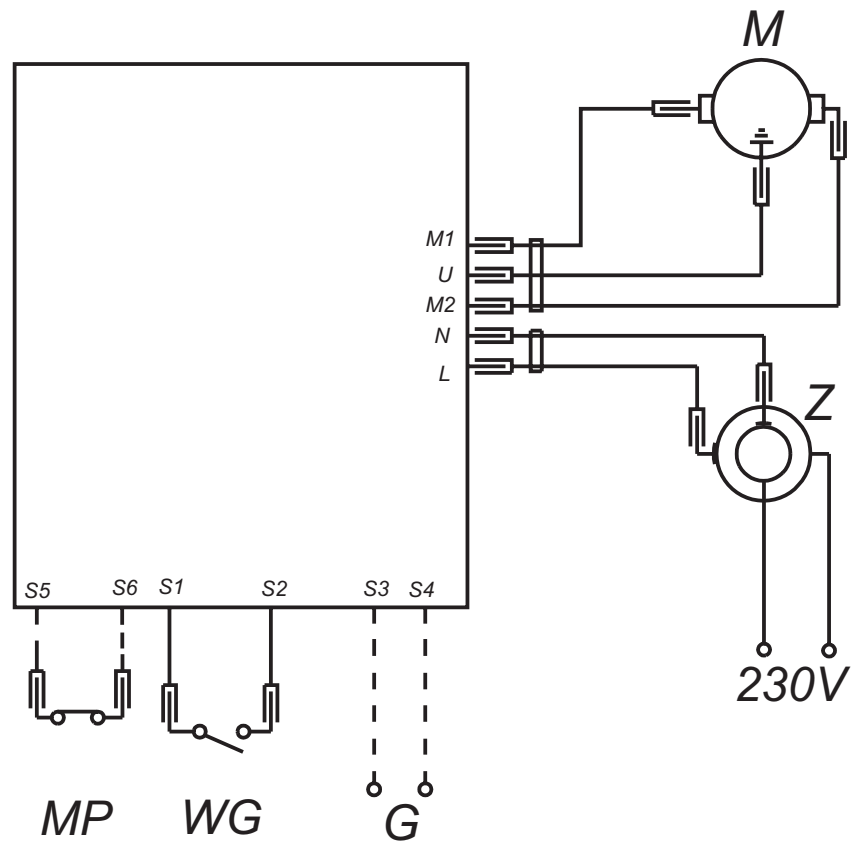

- M -suction unit
- MP -parksystem microswitch
- WG -main switch
- Z -cord winder
- G - electrobrush - socket

VI HOSE HANDLE TYPE 2000.1400

