

I VACUUM CLEANER TYPE ZELMER 321.5.E00E (KOLOR PANTONE 137C) / ZELMER HUNGARY

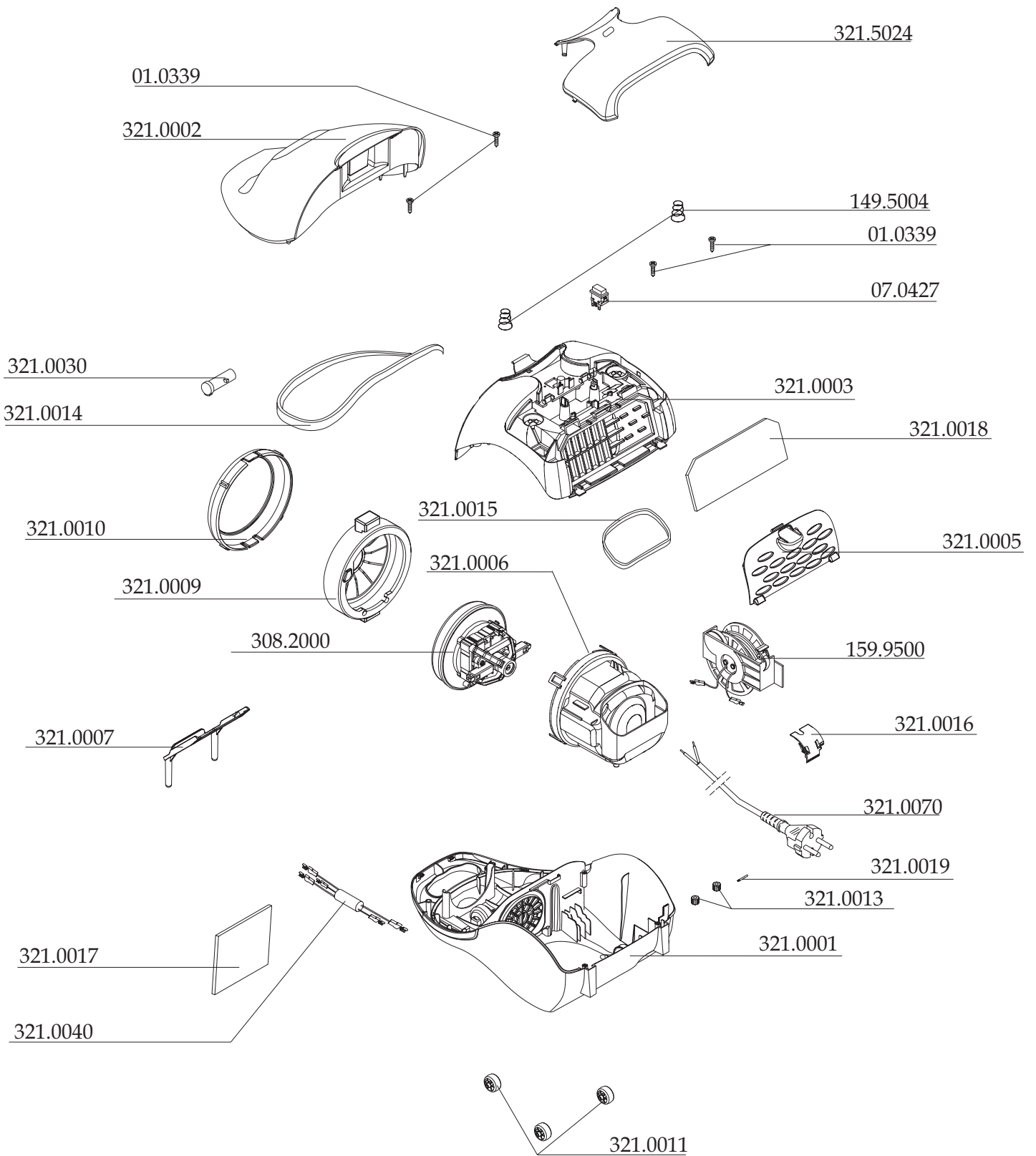

II SUCTION UNIT TYPE 308.2000

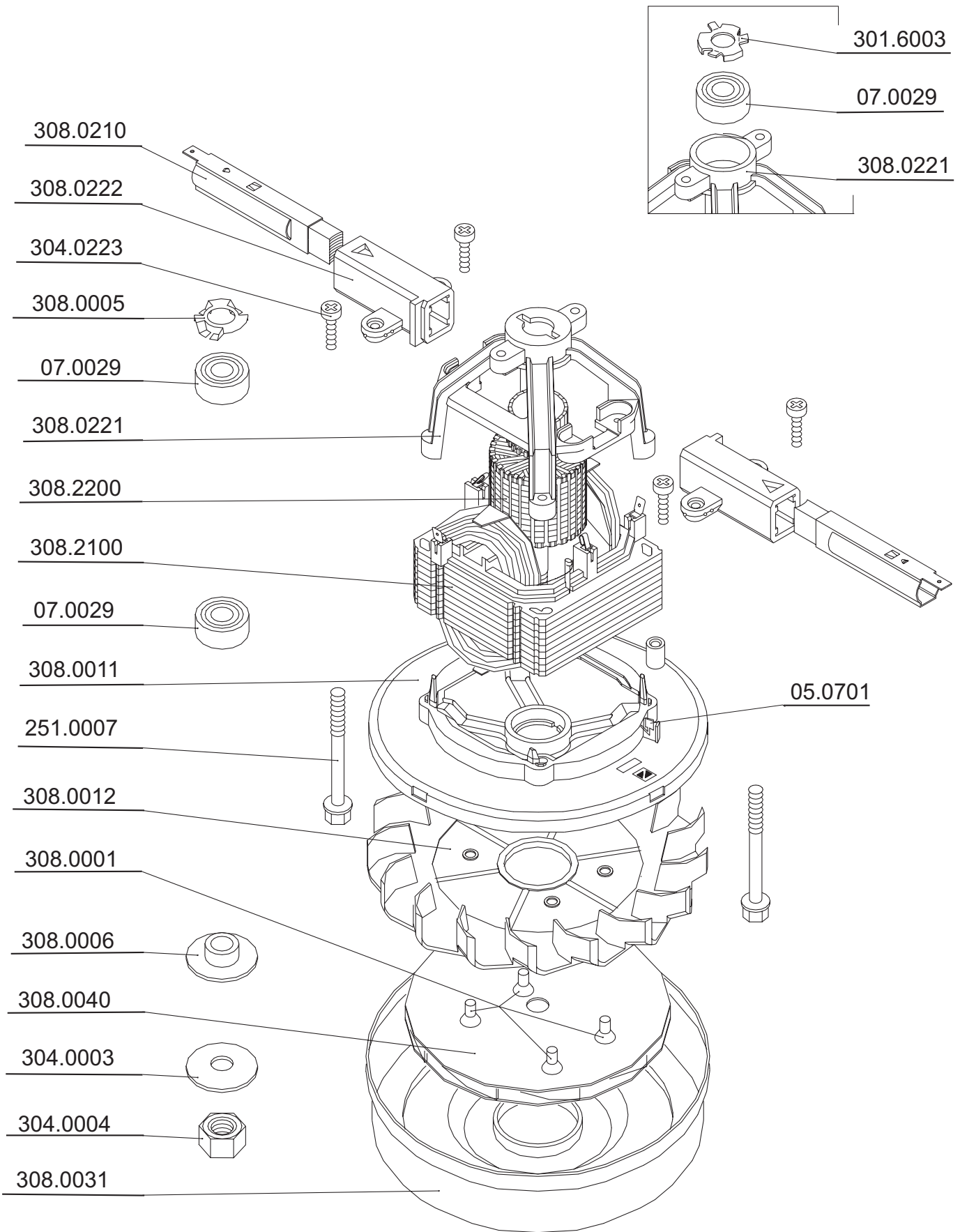

III CORD WINDER 159.9500

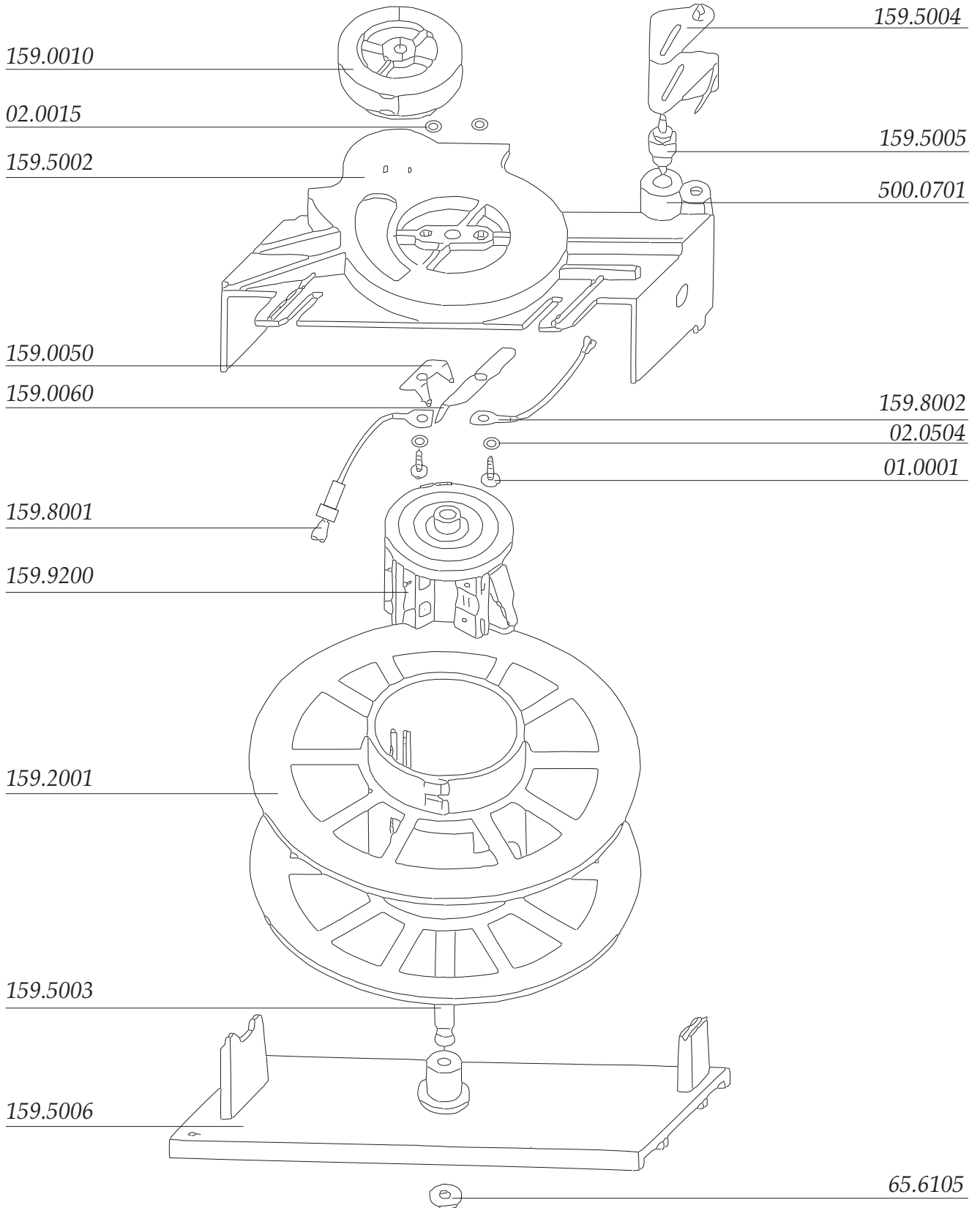

IV VACUUM CLEANER ACCESSORIES
TYPE ZELMER 321.5.E00E
(KOLOR PANTONE 137C) / ZELMER HUNGARY

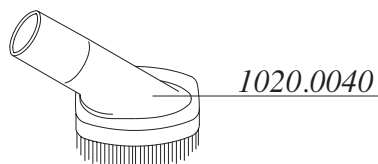
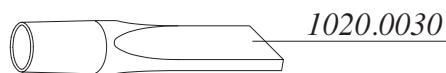
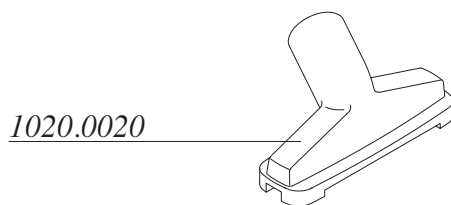
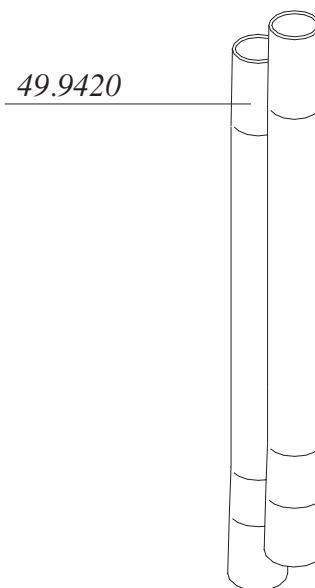
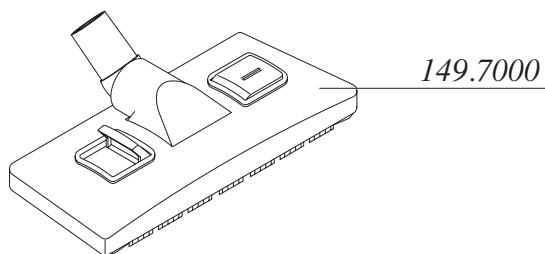
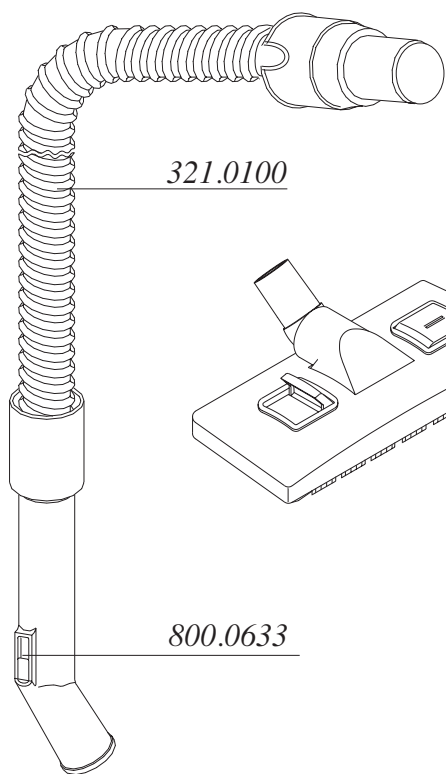
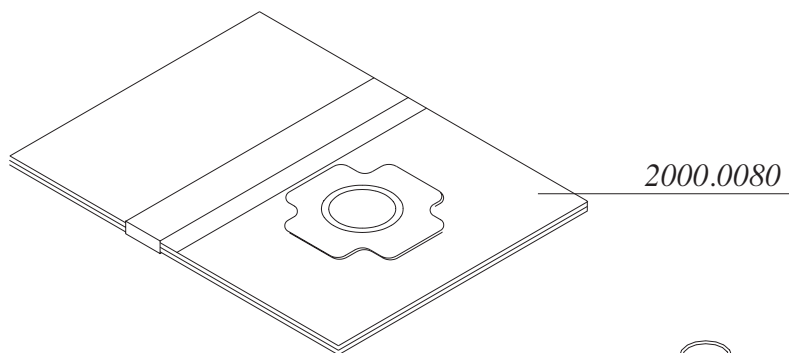
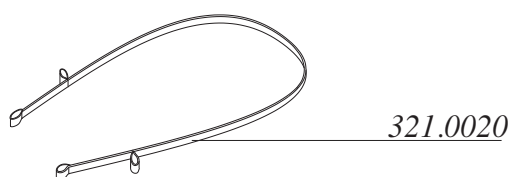

V ELECTRICAL DIAGRAM OF THE VACUUM CLEANER TYPE ZELMER 321.5.E00E (KOLOR PANTONE 137C) /ZELMER HUNGARY

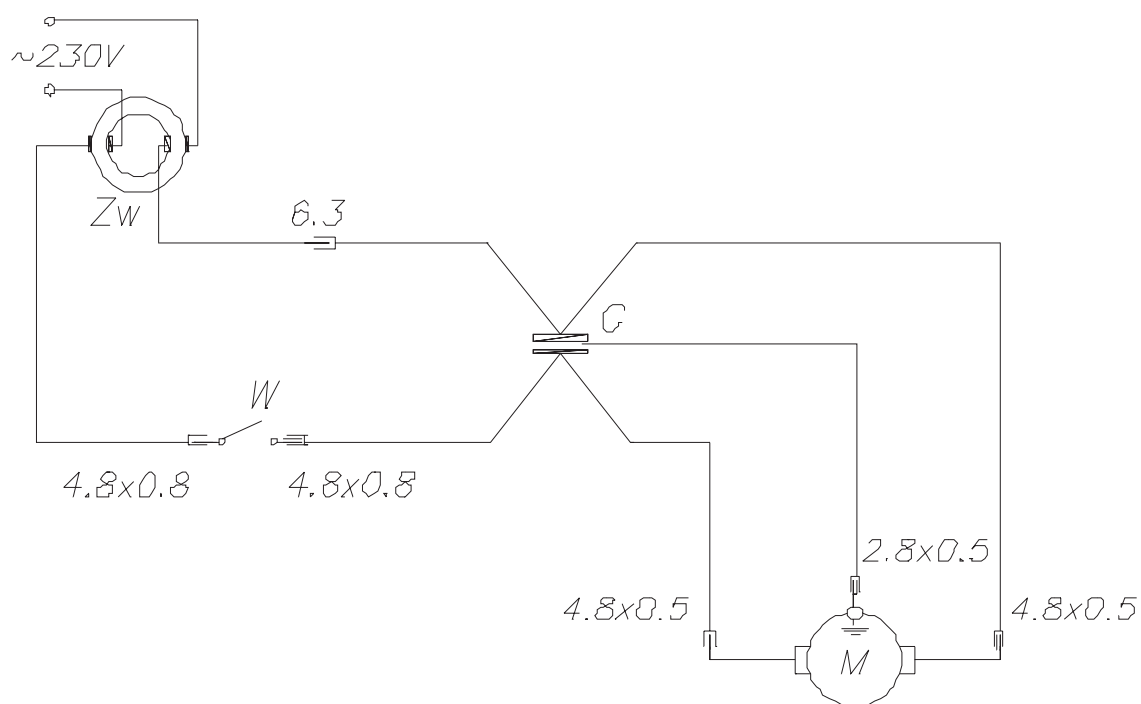

ZW - CORD WINDER
C - CAPACITOR
M - MOTOR
W - MAIN SWITCH