

I VACUUM CLEANER ZELMER TYPE 619.5.B5S (RAL 9005 / SILVER) / ZELMER HUNGARY

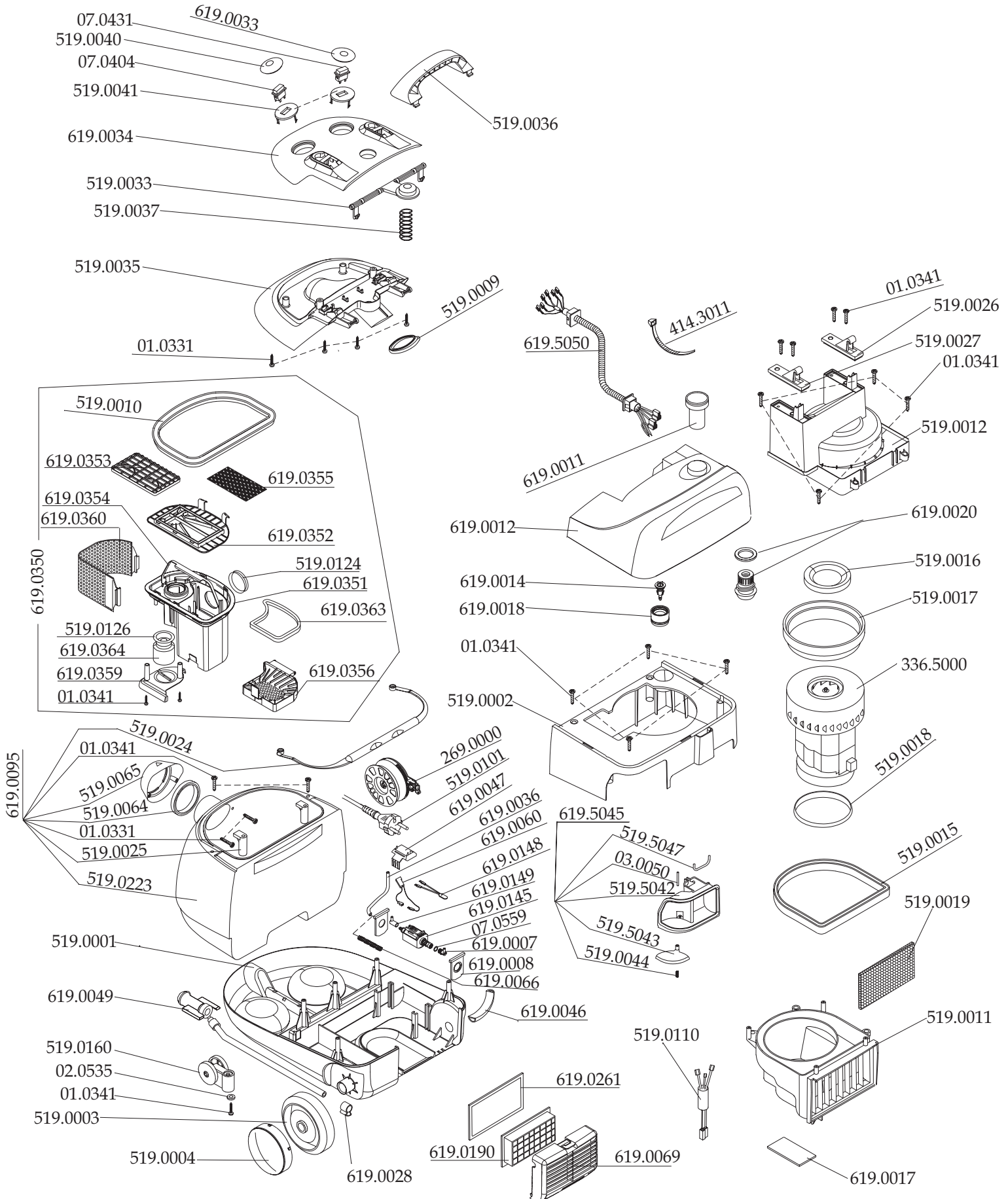

II SUCTION UNIT 336.5000

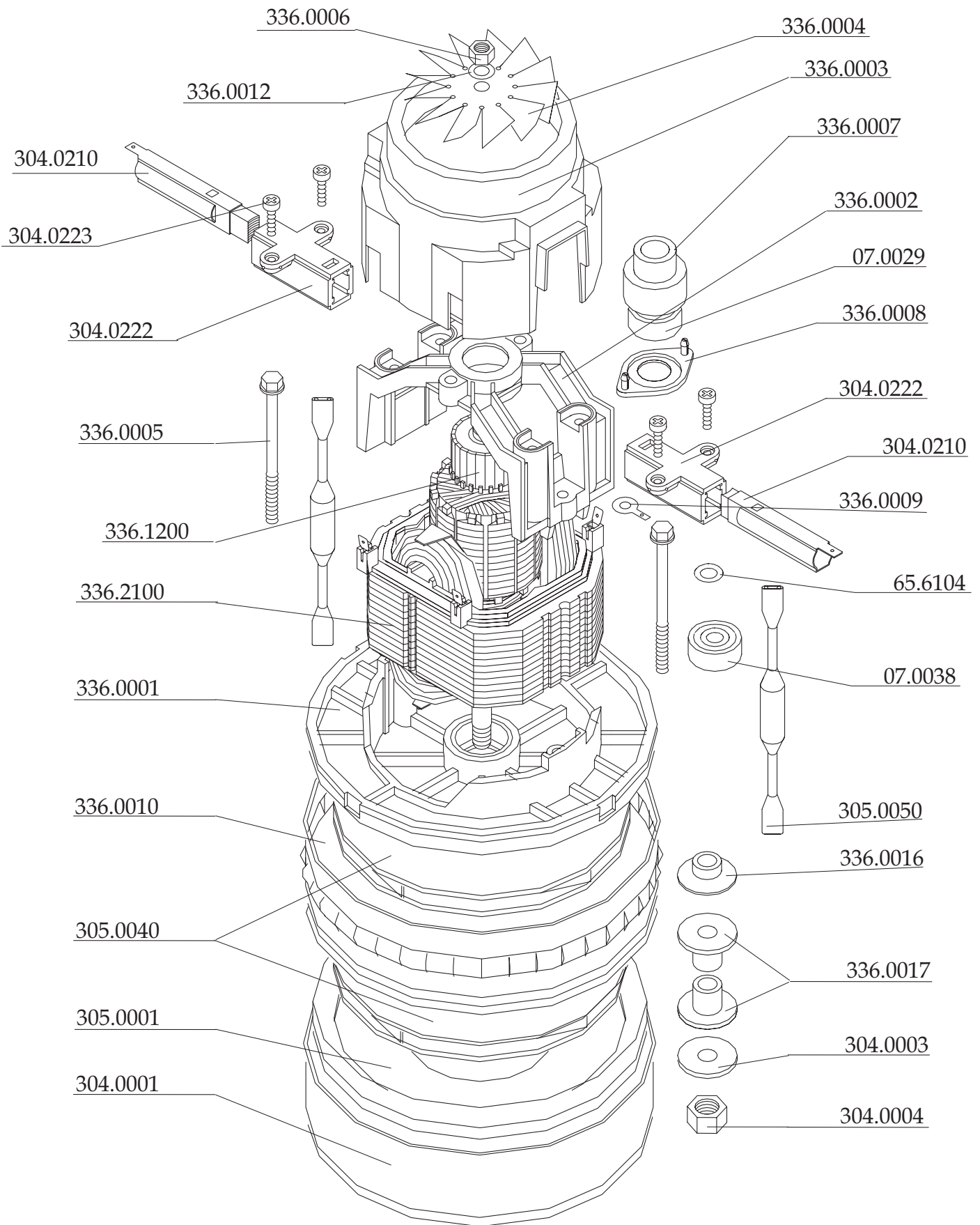

III CORD WINDER 269.0000

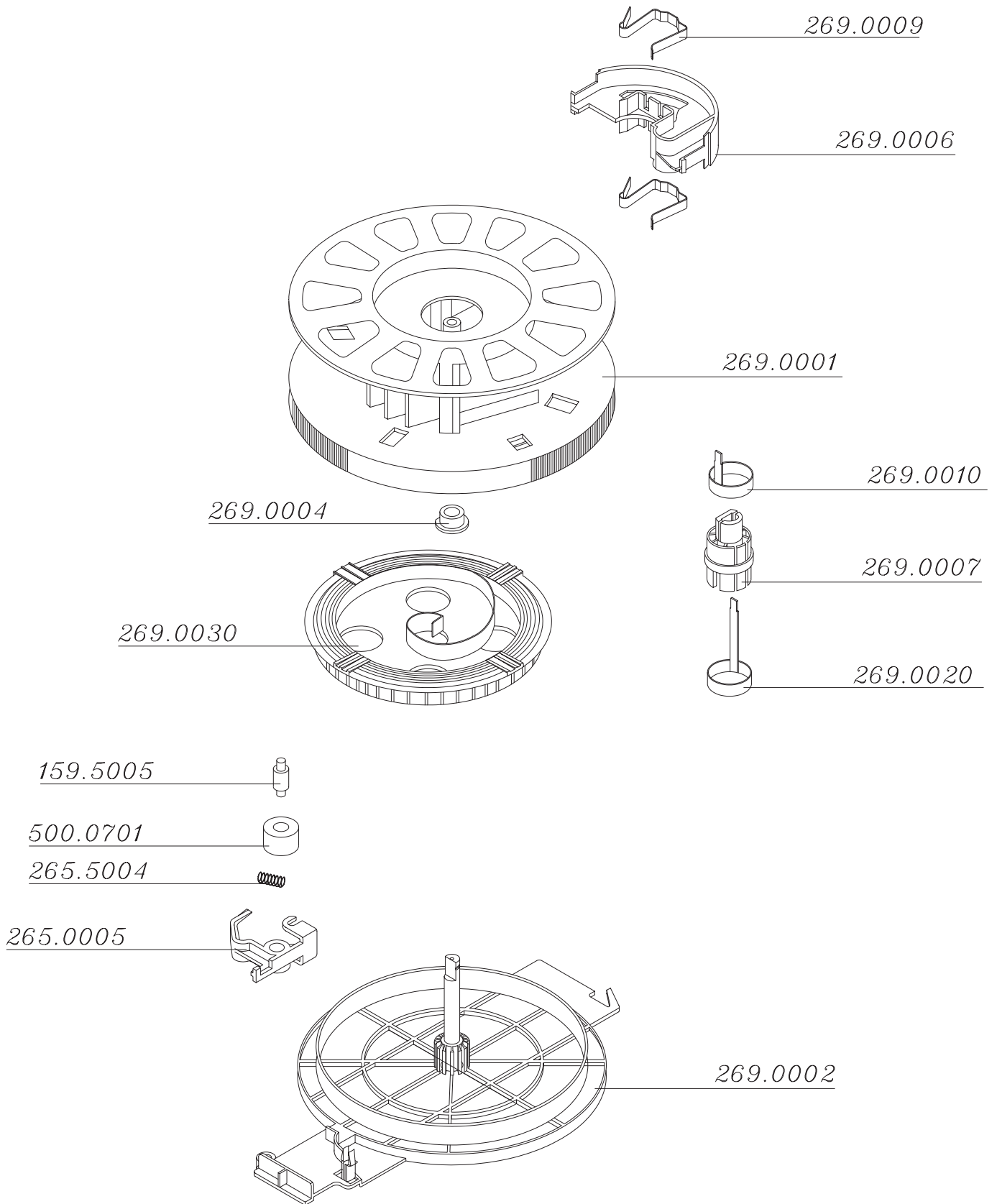

IV VACUUM CLEANER ACCESSORIES

ZELMER TYPE 619.5.B5S (RAL 9005 / SILVER)

ZELMER HUNGARY

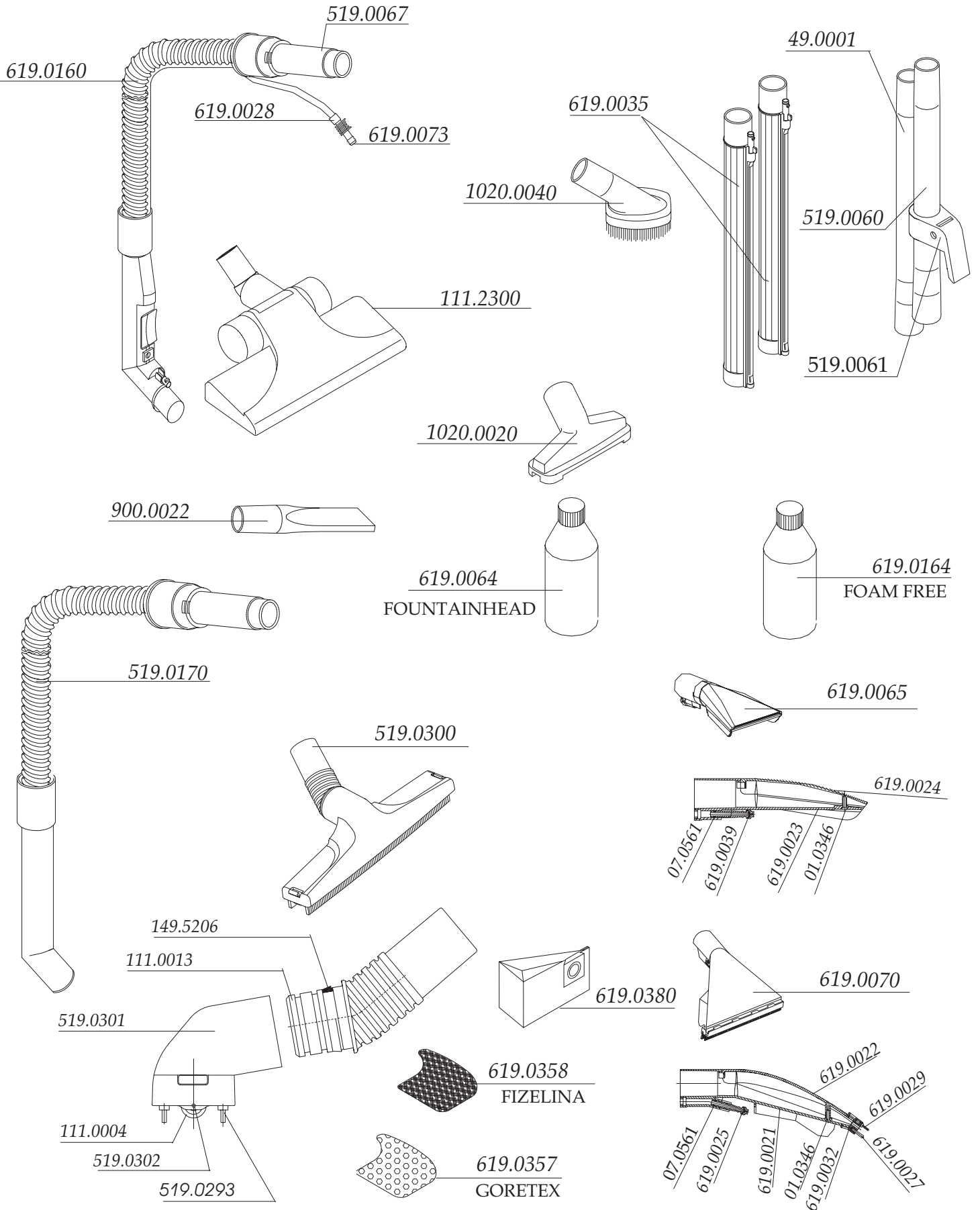

**V ELECTRICAL DIAGRAM OF THE VACUUM CLEANER
ZELMER TYPE 619.5.B5S (RAL 9005 / SILVER)
ZELMER HUNGARY**

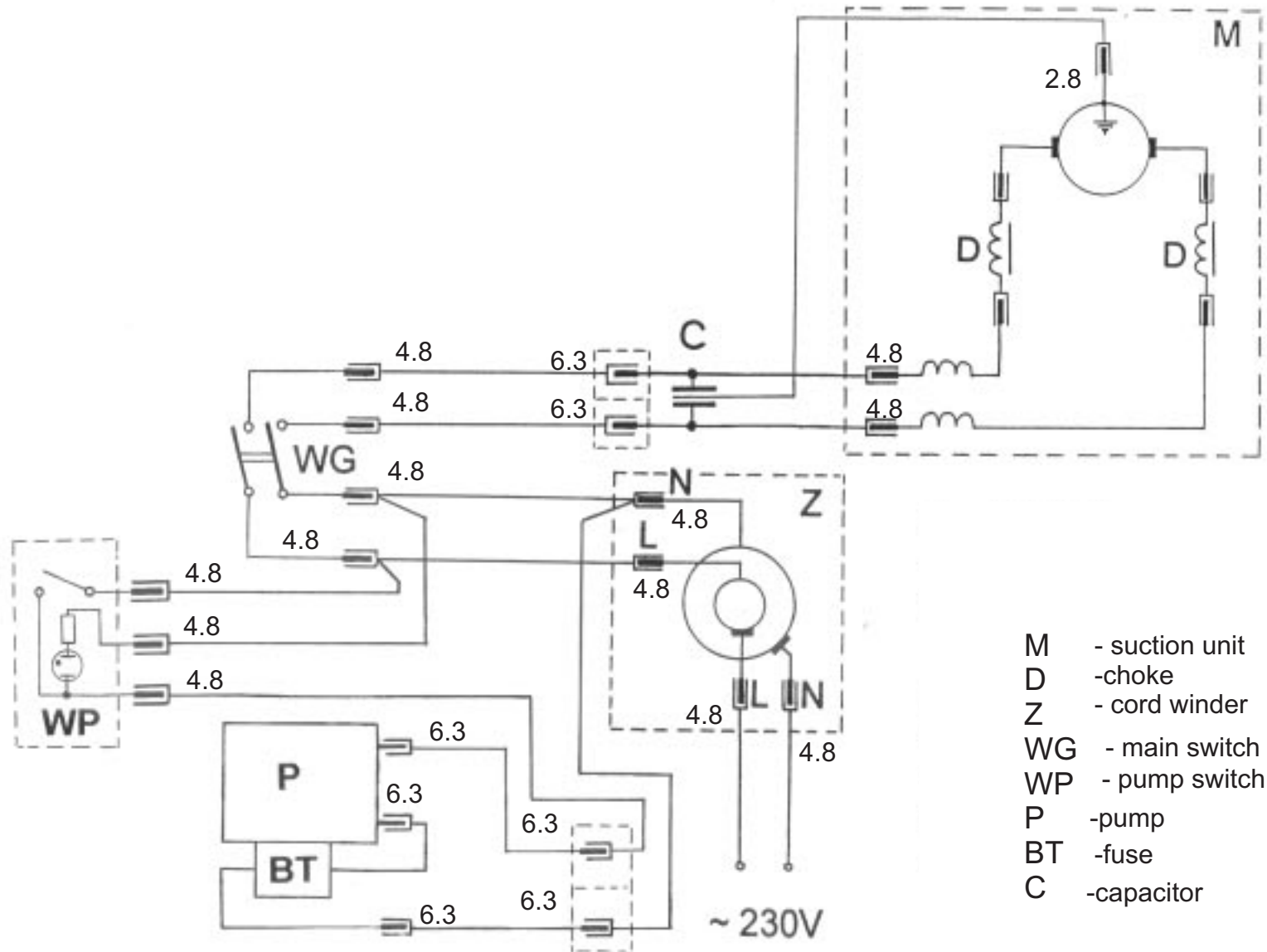

- M - suction unit
- D -choke
- Z - cord winder
- WG - main switch
- WP - pump switch
- P -pump
- BT -fuse
- C -capacitor